**User's
Manual**

**Model BT200
BRAIN TERMINAL**

BRAIN TERMINAL

BlankPage

CONTENTS

INTRODUCTION	1	5. USING THE BT200 FUNCTIONS	5-1
1. PRECAUTIONS	1-1	5.1 SETTING UP DATA IN A BATCH (UPLOAD/DOWNLOAD)	5-1
1.1 CHECK THE CONTENTS OF THE PACKAGE	1-1	5.2 USING PRINTER FUNCTIONS (BT200-P00)	5-4
1.2 PRECAUTIONS IN HANDLING	1-2	5.3 OFFLINE FUNCTIONS	5-8
2. INTRODUCTION TO BT200	2-1	6. MAINTENANCE	6-1
2.1 WHAT THE BT200 CAN DO	2-2	6.1 REPLACING BATTERIES	6-1
2.2 SPECIFICATION	2-3	6.2 LOADING ROLL PAPER	6-3
2.3 COMPONENT NAME	2-5	7. TROUBLESHOOTING	7-1
2.4 DIMENSIONS	2-6	APPENDIX A	A-1
3. CONNECTION	3-1	APPENDIX B	A-4
3.1 PLUGGING THE CABLE INTO THE BT200 ..	3-1	REVISION RECORD	
3.2 CONNECTION WITH BRAIN SERIES INSTRUMENTS	3-2		
4. BT200 BASIC OPERATIONS	4-1		
4.1 KEY LAYOUT AND DISPLAY	4-1		
4.2 KEY DESCRIPTIONS	4-2		
4.3 BT200 FUNCTION CONFIGURATION	4-5		
4.4 BASIC OPERATIONS	4-6		

INTRODUCTION

Thank you for choosing the BT200 BRAIN TERMINAL.

This user's manual describes how to operate the model BT200-N00 BRAIN TERMINAL and the model BT200-P00 BRAIN TERMINAL with printer, and presents cautionary notes on usage. The contents display on the BT200 and the items that can be set by the BT200 depend on the types of instruments used with the BT200. Please read this manual before using the instrument.

Note that changes in the specifications, construction, or component parts of the BT200 may not be reflected in this manual at the time the changes are made, provided that postponement of revisions will adversely affect functional or performance. Please keep the above in mind when using this manual.

If a problem arises, please inform us of the nature of the problem and the circumstances under which it developed, including the model (MODEL), specification and optional codes (SUFFIX), serial number (NO.) from the data plate (Figure 2.2). Any diagrams, data and other information you can include in your communication will be helpful.

Yokogawa cannot take responsibility for any loss of instrument function that results from repair undertaken independently by the customer.

In case of problems, contact the Yokogawa representative from which the instrument was purchased, or the nearest Yokogawa office.

* Related Manuals and Document Code

DPharp EJ Series	IM 01C20B01-01E
DPharp EJA Series	IM 01C22B01-01E
UNIΔMARKII/COM-B	IM 01C05N00-01E
ADMAG	IM 01E06C01-01E
ADMAG AE	IM 01E07B00-E
YEWFLO*E	IM 01F02B04-01E
DigitalYEWFLO	IM 01F06A00-01E
YTA Series	IM 01C50T03-01E
Signal Conditioner	IM 34A09N11-01E

1. PRECAUTIONS

1.1 CHECK THE CONTENTS OF THE PACKAGE

The BT200 BRAIN TERMINAL are thoroughly tested at the factory before shipment. When the BT200 units are delivered, visually check to make sure that no damage occurred during shipment. Also check that the specifications are as specified in the purchase order by comparing those with the Model and Specification Codes in section 2.2

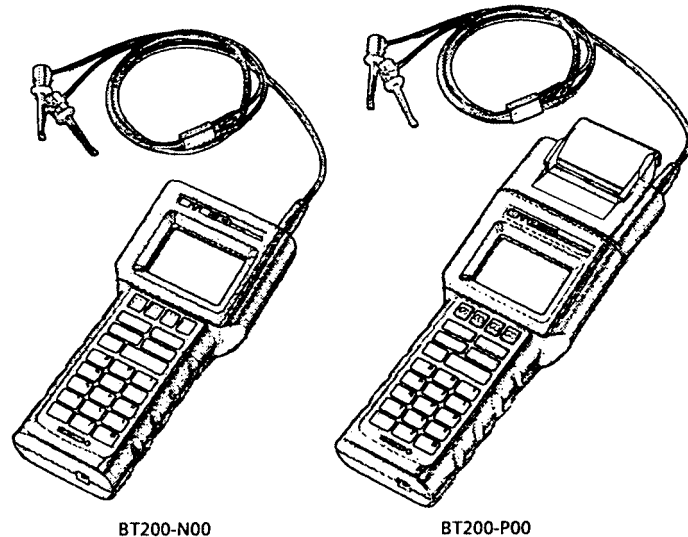

Figure 1.1 BT200

1.2 PRECAUTIONS IN HANDLING

(1) WHERE TO STORE

Store the unit in places meeting the following conditions:

- Places not exposed to rain or water.
- Ambient storage conditions
Ambient temperature: -15 to 60°C (5 to 140°F)
Ambient humidity:
BT200-N00 ... 5 to 95%RH at 40°C (104°F)
(free from condensation)
BT200-P00 30 to 80%RH at 40°C (104°F)
(free from condensation)

(2) HANDLING NOTES

a. Working temperature and humidity ranges

BT200-N00

Ambient temperature: -15 to 55°C (5 to 131°F)

Ambient humidity: 5 to 95%RH at 40°C (104°F)
(free from condensation)

BT200-P00

Ambient temperature: 0 to 50°C (32 to 122°F)

Ambient humidity: 30 to 85%RH at 40°C (104°F)
(free from condensation)

- Do not leave the unit exposed to direct sunlight for an extended period of time.
 - The LCD (liquid crystal display) may appear dark or the unit may be disabled due to loss of the battery capacity at ambient temperatures below -15°C. (5°F)
- b. The unit is not waterproof.
Cover the unit against water when using it outdoors while it is raining.
Do not allow the unit to fall into water.
- c. Note on using a transceiver
While the unit and the associated equipment are fully protected against high-frequency noise interferences, a transceiver used near the unit and the associated equipment or near their cables could impart high-frequency noise interferences to them. When using a transceiver for the first time, check its possible effects on the transmission loop by bringing it closer to the unit, starting at a point several meters away, to locate the range of safety.

d. Following communication is not permitted as it may result communication error or indication error:

- * Connecting more than two BRAIN Terminals to one BRAIN instrument simultaneously.
- * Simultaneous communication by BRAIN Terminal and DCS.

(3) POWER SUPPLY

a. Note on using dry batteries

- The BT200 model on a standard configuration comes complete with five alkali batteries. The unit as shipped, however, is not loaded with these batteries. Before starting to use the BT200, load the batteries shipped under the same cover as instructed in Section 6.1, “Replacing Batteries.”
- Use batteries of a specified voltage (1.5V).
- To avoid possible leaks, remove batteries from the unit before leaving it out of service for an extended period of time.
- In the case of the model with printer, printed characters may become faint when batteries except alkali type are used.

b. Duration of continuous operation

- When running the unit from alkali batteries: 50 hours least (if the printer is not used).
- If the printer is used, the duration of continuous operation is reduced according to the rate of printout (about 10 hours/1,000 lines).

c. Low-voltage indicator

- The BT200 turns on its BATTERY indicator when the battery voltage falls. Replace the batteries whenever the BATTERY indicator is on.

d. Autopower-off feature

- The BT200 will switch itself off automatically when no key access is made for five minutes or longer.

(4) CAUTION for INTRINSICALLY SAFE TYPE

- Please make sure to refer to “APPENDIX B” for Intrinsically Safe Type.
- Intrinsically Safe type can not be modified to equip optional printer afterward.
- Intrinsically Safe Type can not communicate by using communication cable with 5-pin connector.
- Please use the specified battery for Intrinsically Safe Type.

(5) EMC CONFORMITY STANDARDS

CE ,  N200

EN61326, AS/NZS 2064

2. INTRODUCTION TO BT200

The BT200 BRAIN TERMINAL is a portable terminal used in a 4 to 20 mA DC signal line connected to a BRAIN instrument (*1).

The 4 to 20 mA DC signal line between the BT200 and the BRAIN instrument can be superimposed with a communication signal to achieve two-way communication.

Working as a master, the BT200 Permits:

1. Setting and changing parameters for the BRAIN instrument
2. Monitoring PV and MV values and self-check information on the BRAIN instrument, and
3. Directing the BRAIN instrument to enter the constant current output mode.

(*1) BRAIN instrument

Any instrument in support of BRAIN communications, including field instruments, such as differential pressure and pressure transmitters (DPharp, UNIΔMARKII/COM-B), vortex flow meters (YEWFLO style E, DigitalYEWFLO), magnetic flow meters (ADMAG, ADMAG AE) and temperature transmitters (YTA Series), and CENTUM-XL signal conditioners (SC).

2.1 WHAT THE BT200 CAN DO

The BT200 offers the following exclusive features:

Feature	Description
Low-voltage alarm	Turns on the BATTERY indicator when the battery voltage falls.
Autopower-off	Switches off the BT200 automatically when no key access is made for five minutes or longer.
Security code-based setup protection	Sets a security code to protect setup parameters. Entering the correct security code permits alterations to the setup parameters. The BT200 is shipped without a security code set so, you can alter the setup parameters without having to enter a security code.
Upload/download	(Upload to the BT200) Records the setup data on the BRAIN instrument connected to the BT200 into the BT200's memory in a batch.

	(Download to the instrument) Writes uploaded data to another BRAIN instruments, but not to one having a different model name.
Printout	Supports seven modes of printout, including listing of all parameters and listing of downloaded data.
ID (identification code) setup	Sets an identification code for the BT200.
Language selection (between English and Japanese)	Supports both English and Japanese versions of operational messages. The BT200 is shipped with the message mode set to English.
LCD contrast control	Permits controlling the LCD contrast through startup and utility panels.
Print density control	Permits controlling the printout density through a utility panel. the print density level can be visually verified from test printout.

TO201.EPS

2.2 SPECIFICATION

Equipment Specifications

Applicable Equipment

DPharp, UNIA/COM, YA63
ADMAG, ADMAG AE
YEWFLO Style E, DigitalYEWFLO
YTA Series
JUXTA, Signal Conditioner

Communication Signal Connection:

Dedicated cable, 1.1 m long(3.6 ft)

Communication Line:

Line length: Up to 2 km (1.24 mile)(0.75 to 1.25 mm² instrumentation cable)
Load resistance: 250 to 600 Ω (including cable resistance)
Load capacitance: 0.22μF or less
Load inductance: 3.3 mH or less
Power line spacing: 15 cm (6 inch) or more (avoid parallel wiring.)

Display: LCD dot matrix, 21 characters × 8 lines

Controls: Membrane switches (four function keys, 20 general operation keys, and one power switch)

Printer (BT200-P00): Thermal paper type

Power Supply: Five AA 1.5 V dry alkali batteries (LR6/AM3(N))

Dimensions:

BT200-N00 . . . 228×110×51 mm
(9.0×4.3×2.0 inch)

BT200-P00 . . . 321×110×61 mm
(12.6×4.3×2.4 inch)

Approximate Weight:

BT200-N00 . . . 510 g (1.12 lb)
BT200-P00 . . . 700 g (1.54 lb)

Functional Specifications

Basic Functions:

- Setup, alteration, and display of parameters BRAIN communication.

Additional Functions:

- Batch upload/download of data
- Setpoint Protection: Security code enter is required to alter setpoints.
- Battery Alarm ... An alarm message appearing on the LCD signals low battery voltages.

- Automatic Power-off ... The terminal switches off automatically if no key access is made for approximately 5 minutes.
- LCD contrast adjustment
- Printing (BT200-P00)

Printout Information

- All parameter lists
- Parameter list within each menu item
- Setup change data list
- Uploaded data list
- Display images
- Self check list

MODEL AND CODE

Model	Suffix codes	Description
BT200	BRAIN Terminal
Printer	-N	With no printer
	-P	With printer
—	00	Always 00
Options		/□□

T0202.EPS

OPTIONS

Item	Description	Code
Communication Cable with 5-pin connector	for SC (Signal conditioner)	/C1 (Note 1)
CSA Intrinsically Safe Approval	Applicable only for model BT200-N00 See Appendix B.	/CS1 (Note 1) (Note 2)

T0203.EPS

Note 1: Optional Code /CS1 can not be combined with /C1.

Note 2: Applicable only for model BT200-N00.

PART NUMBERS

Item		Parts No.
Communication Cable	with IC clips	F9182EA
	with alligator clips	F9182EB
	with 3-pin connector	F9182ED
	with 5-pin connector	F9182EE
Roll paper		F9182DS
Handy carrying case		F9182BP

T0204.EPS

2.3 COMPONENT NAME

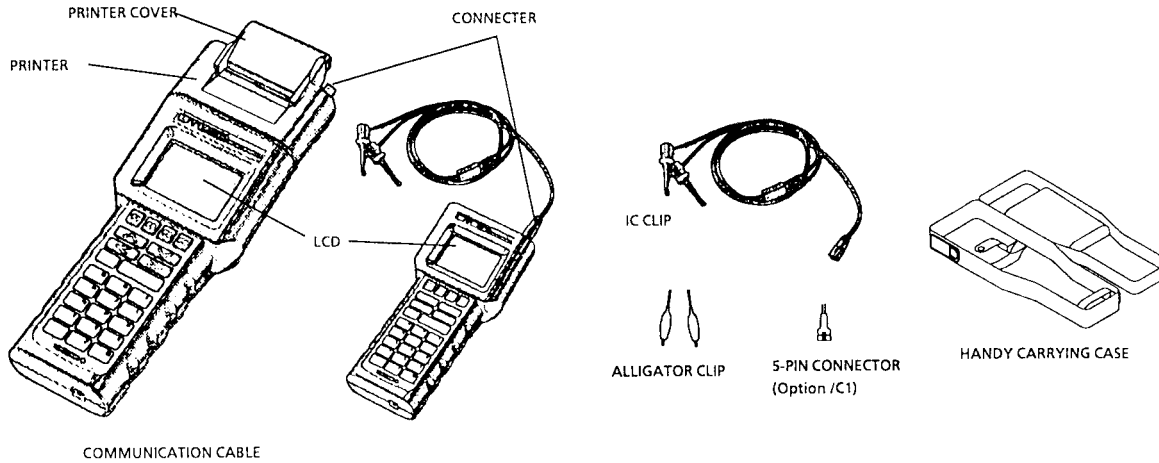

Figure 2.3 Component Name

2.4 DIMENSIONS

MODEL BT200-N00

MODEL BT200-P00

Unit: $\frac{\text{mm}}{\text{inch}}$

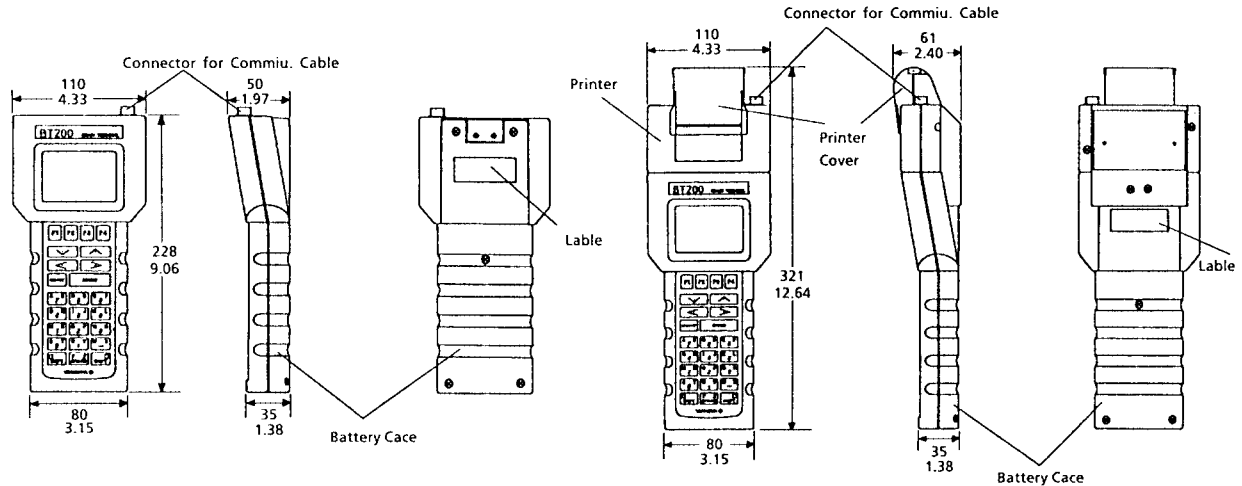

Figure 2.4 Dimensions

3. CONNECTION

3.1 PLUGGING THE CABLE INTO THE BT200

When plugging the dedicated communication cable into the BT200, adjust the up arrow mark ↑ on the cable to the ● mark on the BT200 connector and push the cable into position until a click sounds.

Note: You cannot plug the connector cable for the BT100 into the BT200, because the BT200 and BT100 have different connector structures.

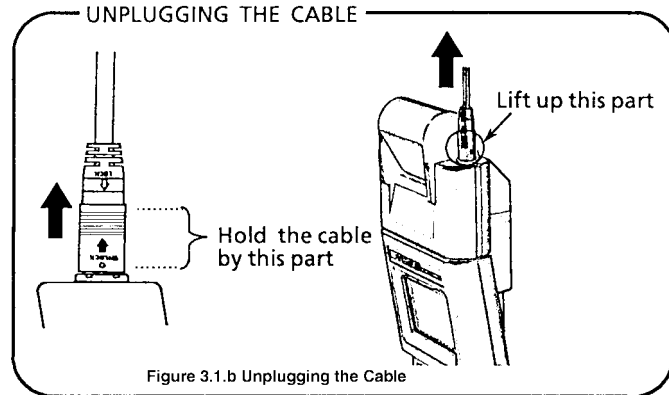
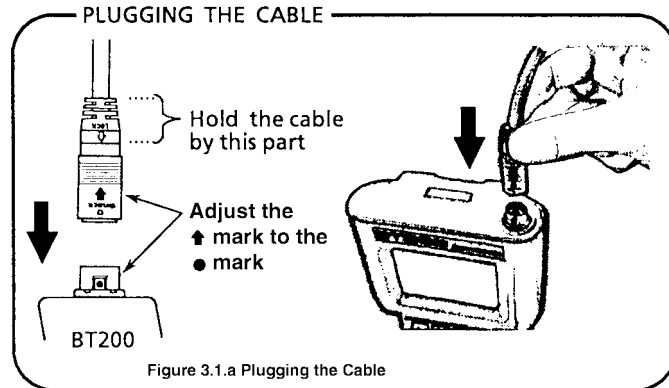

3.2 CONNECTION WITH BRAIN SERIES INSTRUMENTS

(1) CONNECTION IN THE INSTRUMENT TERMINAL BOXES

Some Brain Series equipment terminal boxes have pins for connection to the BRAIN TERMINAL. When connecting the BRAIN TERMINAL to Brain Series equipment in the field, connect as shown in Figure 3.2.a using the BRAIN TERMINAL cable with IC clips. Polarities are marked on the terminal box pins and on the BRAIN TERMINAL cable; however, no damage will occur if they are connected with reverse polarity.

(2) CONNECTION IN RELAY TERMINAL BLOCK

There are no dedicated pins for connecting to the BRAIN TERMINAL in the field relay terminal block or in the meter compartment terminal block. In this case, use the cable with the alligator clips.

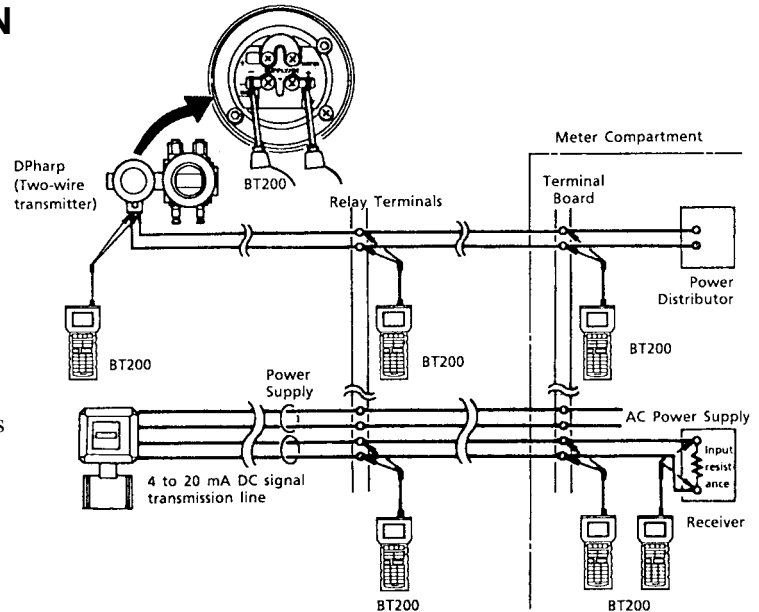

Figure 3.2.a Connecting the BT200

(3) CONNECTION TO SIGNAL CONDITIONER

ESC (signal conditioner communication card) or EXT (extension card) is provided with a BRAIN TERMINAL connector (see Figure 3.2.b). A 5-pin connector cable for the BRAIN TERMINAL is supplied when the BRAIN TERMINAL comes with /C1 options. This cable is also available at extra cost.

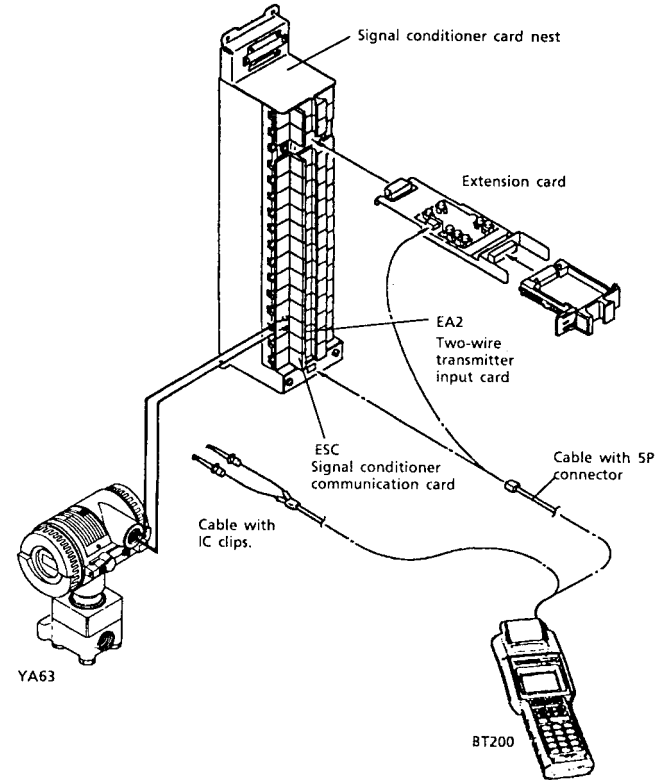

Figure 3.2.b Connection to Signal Conditioner

4. BT200 BASIC OPERATIONS

4.1 KEY LAYOUT AND DISPLAY

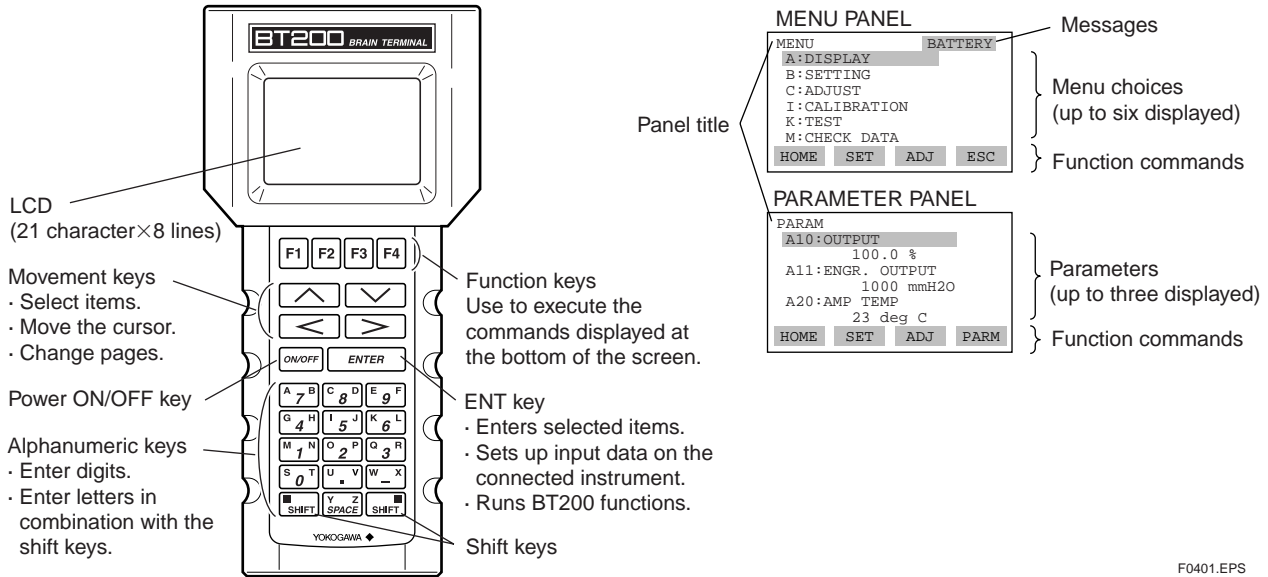

Figure 4.1 Key Layout

F0401.EPS

4.2 KEY DESCRIPTIONS

(1) ALPHANUMERIC KEYS AND SHIFT KEYS

You can use the alphanumeric keys in conjunction with the shift keys to enter symbols, as well as alphanumeric keys.

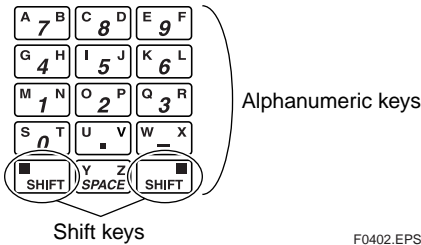

- a) Entering Digits, Symbols, and Spaces (0 to 9 . . .)
Simply press the alphanumeric keys.

Entry	Key-in Sequence
-4	
0.3	

F0403.EPS

- b) Entering letters (A through Z)

Press an alphanumeric key following a shift key to enter the letter shown on the side of the shift key pressed. You need to press the shift key before entering each letter.

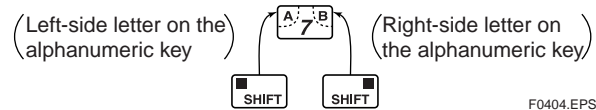

Entry	Key-in Sequence
W	
IC	
J. B	

F0405.EPS

- * Use the function key [F2] **CAPS** to select between uppercase and lowercase (for letters only). The case toggles between uppercase and lowercase each time you press [F2] CAPS.

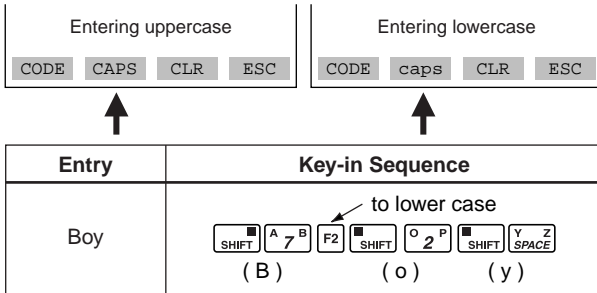

F0406.EPS

- * Use the function key [F1] **CODE** to enter symbols. The following symbols will appear in sequence, one at a time, at the cursor each time you press [F1] CODE:
/ . - , + *) (' & % \$ # " ' !

To enter characters next to these symbols, press [>] to move the cursor first.

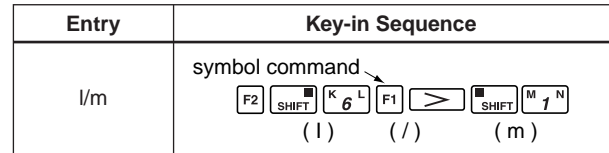

F0407.EPS

(2) FUNCTION KEYS

The functions of the function keys depend on the function commands on display.

FUNCTION COMMAND LIST

(FOR BT200-N00 & BT200-P00)

Command	Function
ADJ	Displays the ADJ menu
CAPS/caps	Selects uppercase or lowercase
CODE	Selects symbols
CLR	Erases input data or deletes all data
DATA	Updates parameter data
DEL	Deletes one character
DIAG	Calls the self-check panel
ESC	Returns to the most recent display
HOME	Displays the menu panel
NO	Quits setup and returns to the previous display
OK	Proceeds to the next panel
PARM	Enters the parameter number setup mode
SET	Displays the SET menu
SLOT	Returns to the slot selection panel
UTIL	Calls the utility panel

T0401-1.EPS

(FOR BT200-P00)

Command	Function
COPY	Prints out parameters on display
FEED	Paper feed
LIST	Lists all parameters in the menu
PON/POFF	Automatic printout mode on or off
PRNT	Changes to the print mode
GO	Starts printing
STOP	Cancels printing

T0401-2.EPS

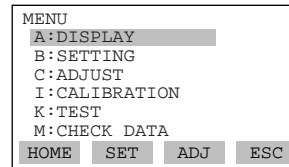

} Function commands

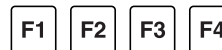

} Function keys

F0408.EPS

4.4 BASIC OPERATIONS

This section illustrates the basic operations of the BT200-P00 (BRAIN TERMINAL with a printer) with reference to online communication with DPharp, for example.

For the BT200-N00, the function commands marked by a corrugated line (⏟) and the messages marked by an asterisk (*) are not displayed.

(1) TURN THE POWER SWITCH ON OR OFF

■ Startup panel

Turn on the BT200, and it comes up with the panel shown below. (The message “Please wait . . . ” will be displayed for seconds after the unit is turned on.)

ON/OFF POWER SWITCH ON

STARTUP PANEL

```
--WELCOME--  
BRAIN TERMINAL  
ID: BT200  
  
check connection  
push ENTER key  
  
UTIL FEED
```

Plug the cable into the instrument and press [ENT].
[F1] UTIL → Call a utility panel (See Section 5.3.)
[F2] FEED → Paper feed (BT200-P00)

ENTER

If connected to
a field
instrument

INITIAL DATA PANEL

```
PARAM  
01:MODEL  
EJ110-DM  
02:TAG NO.  
TABC-101  
03:SELF CHECK  
GOOD  
  
OK
```

If connected to
an SC (signal
conditioner)

SLOT PANEL

```
SLOT  
SLOT NO.  
00  
  
CLR
```

Type the slot number of the
SC and press [ENT].

Slot number
+

ENTER

```
PARAM  
01:MODEL  
EJ110-DM  
02:TAG NO.  
TABC-101  
03:SELF CHECK  
GOOD  
  
SLOT OK
```

[F3] SLOT → Return to slot panel.

F4

or

ENTER

MENU PANEL

```
MENU  
A:DISPLAY  
B:SENSOR TYPE  
  
HOME SET ADJ ESC
```

Check the model name and
tag number of the connected
instrument, and self-check
information associated with it.

(2) DISPLAY PARAMETERS

a) Menu panel operations

The menu panel contains a list of up to six menu choices in each page. Use [<] and [>] to change the pages. Pressing [F1] HOME, [F2] SET, and [F3] ADJ displays the menu in the block.

- [F1] HOME Displays the menu panel.
- [F2] SET Displays the SET menu panel.
- [F3] ADJ Displays the ADJ menu panel.
- [F4] ESC Returns the command panel.
- [ENT] Enters selected menu choice.

DPharp

If the menu choices are blocked (as with DPharp,) the menus are displayed for each block.

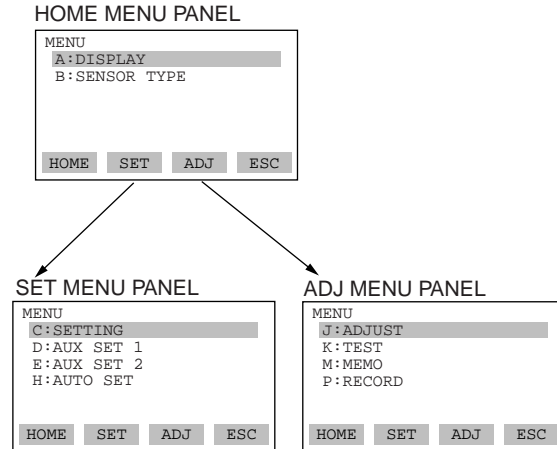

F0411.EPS

- b) Call the parameter panel
 On initial data panel, type [F4] OK or [ENT] to call the starting [HOME menu panel] of menu panel 4.

Select a menu choice from menu panel 4 and press [ENT] to call parameter panel 5.

The parameter panel displays up to three parameters in each page. Use the movement keys [▲], [▼], [←], and [→] to select parameters.

▲	Move the reverse bar up and down to select parameters.
▼	
▶	Change pages.
◀	

F0412.EPS

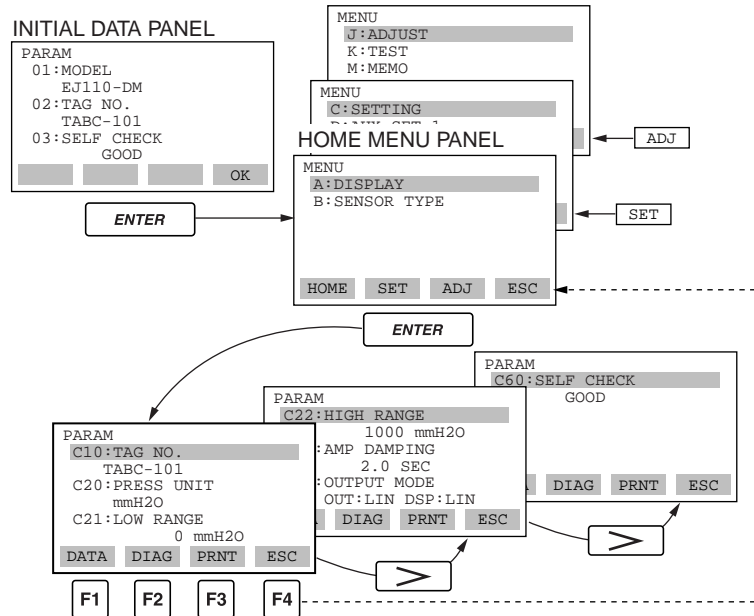

F1	DATA	Updates the current parameter. When you press this key, data is read from the connected instrument for display through telecommunications.
F2	DIAG	Calls the self-check panel. (See Section 4.4(2)c)
F3	PRNT	Calls the parameter print panel. (See Section 5.2(2))
F4	ESC	Exits from the current panel and returns to the previous panel (menu panel).

F0413.EPS

Helpful hint 1

- Typing letters in a panel allows you to make a direct selection of the corresponding menu choices from the panel.

1. While Menu panel is on display, type 'K' to select the choice 'K: TEST.'
2. On a utility panel or function panel, type digits instead to make a direct selection of the corresponding utility functions.

MENU PANEL

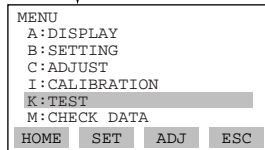
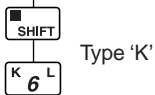
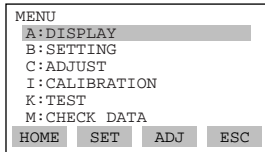

UTILITY PANEL

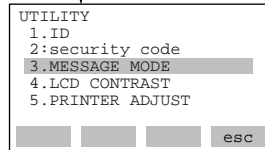
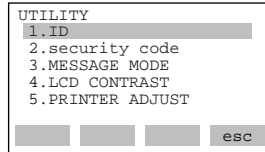

Helpful hint 2

- Following procedure allows you to make a direct selection of the parameter.

① PARAMETER PANEL

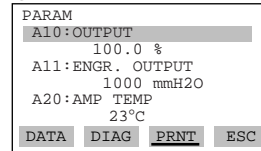

②

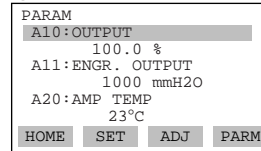

③

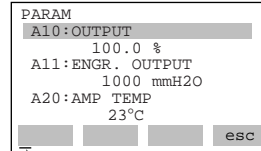

1. Press a shift key on parameter panel ① to change the function commands to the commands shown on panel②.

2. Press [F4] PARM to change the function commands to the commands shown on panel③.

- [F1] HOME →HOME parameter panel.
- [F2] SET →SET parameter panel.
- [F3] ADJ →ADJ parameter panel.
- [F4] PARM →Change the function commands.

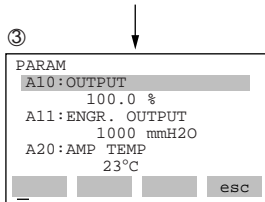

While commands are displayed on panel ③, type the number of a parameter to be displayed and press [ENT] to call the parameter panel for the entered number.

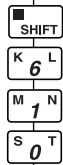

Example: Call the parameter panel 'K10: OUTPUT X%' from panel ③.

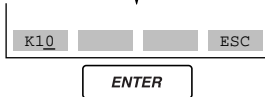

→Type 'K10' and press [ENT].

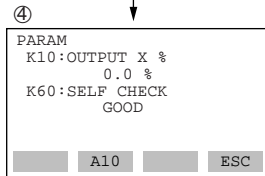

[F2] A10 →Panel ③
 [F4] ESC →Returns the function commands to commands shown on panel ①.

Number of the starting parameter on the panel before the last
 Number of the starting parameter on the previous panel

F0415-2.EPS

c) Call the self-check panel

Press [F2] DIAG on a parameter panel to call a self-check panel. The self-check panel displays self-check information on the connected instrument. This function is not available for signal conditioners.

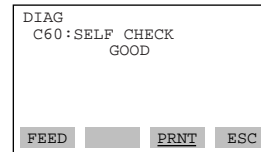
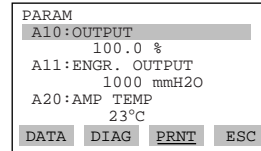

(When errors occur)

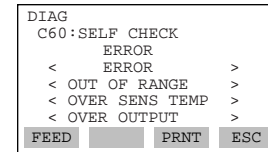

FEED	Paper feed
PRNT	Print (See Section 5.2(6).)
ESC	Returns to parameter panel

F0416.EPS

(3) CHANGE SETUP DATA

To change setup data, select a parameter to change from parameter panel and press [ENT] to call setup panel. If you have set a security code with a utility, that code must be entered.

Example 1

Change the tag number
Current: TABC-101 → EJ-aH01

① PARAMETER PANEL

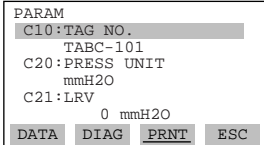

ENTER

1. Select the parameter to change with [A], [v], [<] or [>] and press [ENT].

If you have set a security code, you must enter the security code. (See section (4))

② SETUP PANEL

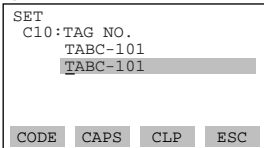

2. Enter data 'EJ-aH01.'

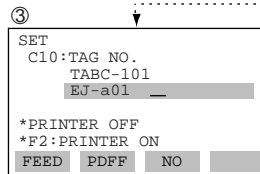
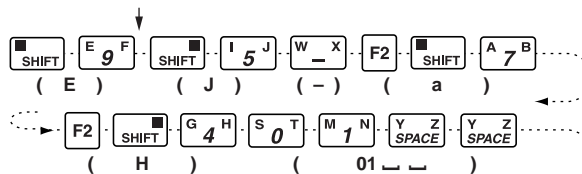

3. Press [ENT].

ENTER

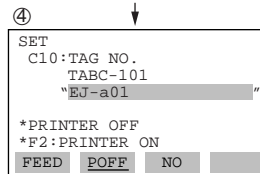

4. The setup data flashes for your verification. Press [ENT] to accept new tag number.
[F3] NO → Cancel the setup procedure.
[F2] POFF → (See Section 5.2)

ENTER

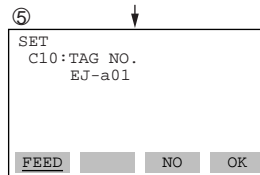

5. The setup procedure is complete. The data on the connected instrument is rewritten.
[F3] NO → Retry the data setup.
[F4] OK → Return to the parameter panel.

Example 2

Change the unit.
Current: mmH₂O → kPa

① PARAMETER PANEL

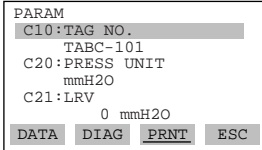

1. Select the parameter to change with [▲], [▼], [←] or [→] and press [ENT].

ENTER

If you have set a security code, you must enter the security code. (See section (4))

② SETUP PANEL

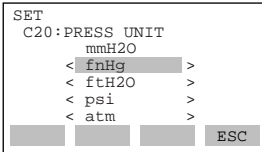

2. Select the setup data with [▲], [▼], [←] or [→] and press [ENT] twice to complete the setup procedure.

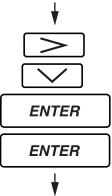

F0418-1.EPS

③ SETUP PANEL

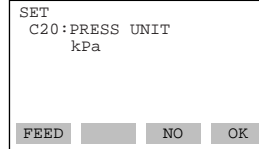

3. The setup procedure is complete.

- [F1] FEED → Paper feed.
- [F3] NO → Retry the data setup.
- [F4] OK → Return to the parameter panel.

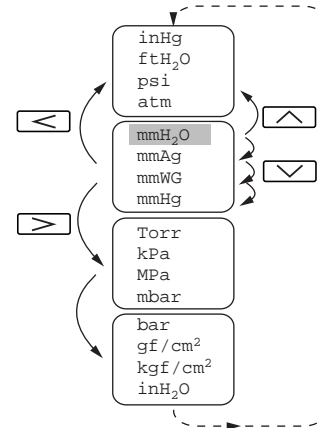

F0418-2.EPS

(4) ENTER A SECURITY CODE (IF ONE HAS BEEN SET)

To alter setup data for the first time after switching on the BT200, select the security code setup panel. You must type the correct security code, in order to rewrite parameters for the connected instrument.

You must to type the security code only once after the BT200 is switched on. Reentry is not needed until you switch off the BT200.

PARAMETER PANEL

```
PARAM
C10:TAG NO.
      TABC-101
C20:PRESS UNIT
      mmH2O
C21:LRV
      0 mmH2O
DATA  DIAG  PRNT  ESC
```

ENTER

SECURITY CODE SETUP PANEL

```
SECURITY
ID:BT200
SECURITY CODE
:***_
      CLR  ESC
```

ENTER

SETUP PANEL

```
SET
C10:TAG NO.
      TABC-101
      TABC-101
CODE  CAPS  CLR  ESC
```

1. Select 'C10: TAG No.' and press [ENT] to change the tag number. 'SECURITY CODE SETUP Panel' is displayed only if the tag number is changed for the first time.

2. Type the security code (four digits) and press [ENT].

* If you type the wrong security code and press [ENT], the message "incorrect CODE" is displayed. Type the correct security code.

5. USING THE BT200 FUNCTIONS

5.1 SETTING UP DATA IN A BATCH (UPLOAD/DOWNLOAD)

Where a number of instruments are used, many units might have virtually identical settings. In this situation, the setup procedure can be simplified by copying the settings for one instrument into another in a batch, then making necessary modifications to that data. This setup technique helps standardize the operating state of each individual instrument and reduces the chances of improper settings.

This function does not apply to certain instruments, such as signal conditioner cards.

(1) COPY TO THE BT200 IN A BATCH (UPLOAD)

First, it is necessary to copy the settings for a particular instrument into the BT200 in a batch. The items from the SET menu can be copied.

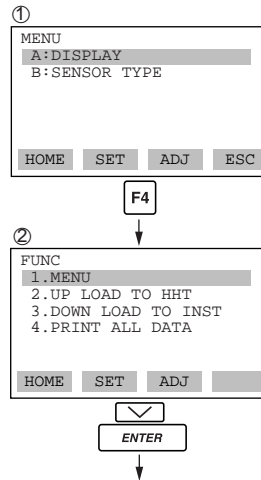

1. Connect the BT200 to the instrument and make it ready for communication. Press [F4] ESC on the menu panel to call panel ②.

2. Select '2. UPLOAD TO HHT' and press [ENT]

HHT(Handheld terminal): BT200

F0501-1.EPS

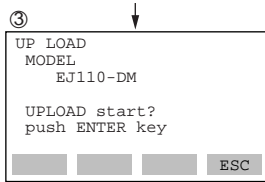

3. The model name of the connected instrument is displayed, check it and press [ENT].

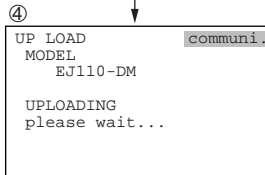

4. An upload is executed and a transfer starts. Panel 4 is displayed while the transfer is in progress.

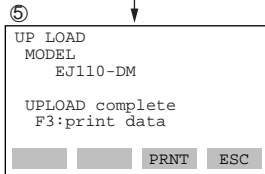

5. The transfer is complete when panel 5 appears.
 [F3] PRNT → Print uploaded data. (See section 5.2(5).)
 [F4] ESC → Return to the function panel.

F0501-2.EPS

Because the data is written to the BT200's nonvolatile memory, it is preserved intact even when the terminal is switched off.

(2) GLOBAL COPY (DOWNLOAD)

Downloading copies the settings stored in the BT200 into other instruments in a batch, but not into different models.

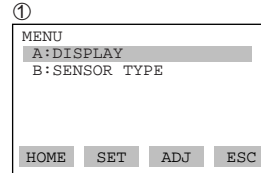

1. Connect the BT200 to the other instrument and make it ready for communication. Press [F4] ESC on the menu panel to call panel 2.

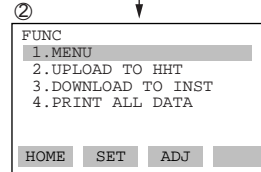

2. Select '3. DOWNLOAD TO INST' and press [ENT].



F0502-1.EPS

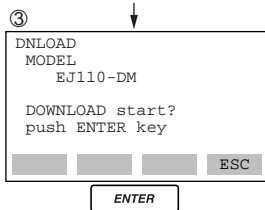

3. Check the model name displayed on panel ② and that of the instrument into which data is downloaded. Data cannot be downloaded into an instrument having a different model name. Press [ENT] to execute a download.

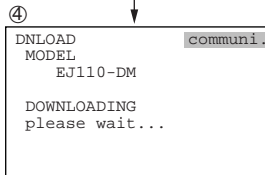

4. A download is executed and a transfer starts. Panel ④ is displayed while the transfer is in progress.

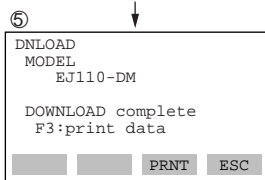

5. The transfer is complete when panel ⑤ appears.
[F3] PRNT → Print uploaded data. (See section 5.2(5).)
[F4] ESC → Return to the function panel.

F0502-2.EPS

* If the model name is unmatched, the message “MODEL mismatch” is displayed. Press [F4] ESC return to panel ②.

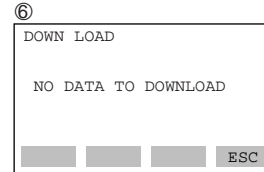

F0503.EPS

* When there is no data to download (because an upload has not been successfully ended), panel ⑥ is displayed, indicating that downloading is not operable.

5.2 USING PRINTER FUNCTIONS

(BT200-P00)

The BT200-P00 BRAIN TERMINAL with a printer can print in the following modes:

1. Listing of setup data and changed data	Prints out old and new versions of the data on the setup panel.
2. Listing of display parameters	Prints out data displayed on a panel.
3. Listing of all parameters from a menu	Prints out all the parameters, from A10 to A60, for menu choice A, for example.
4. Listing of all parameters	Prints out an entire list of parameters.
5. Listing of self-check information	Prints out a list of self-check information (such as error information) designated by the DIAG key.
6. Listing of uploaded or downloaded data	① Uploaded data list prints out data after it has been uploaded. ② Downloaded data list prints out data after it has been downloaded.

T0501.EPS

(1) PRINTING CHANGED SETUP DATA

① SETUP PANEL

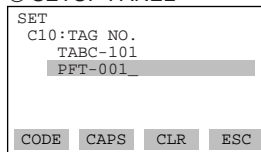

ENTER

②

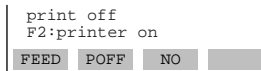

F2

③

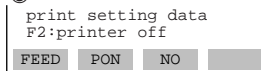

ENTER

④

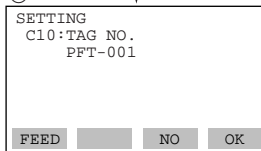

1. Enter new data into the setup panel and press [ENT] to select the setup data verification panel ②.

2. Press [F2] **POFF** changes to **PON**. (To turn on the printout mode.)

3. Press [ENT] to set the update data in the instrument and print out both the old and new versions of data.

The printout covers the parameter number, name, old data, and new data.

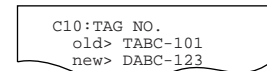

(Sample printout)

F0504.EPS

(2) PRINTING DISPLAY PARAMETERS

①

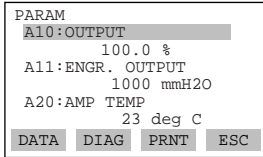

1. Press [F4] PRNT on parameter panel ① to change the function commands.

F3

②

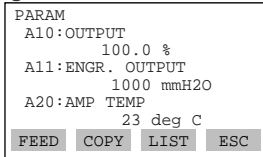

2. Press [F2] COPY to print out only the parameters appearing on the display panel.

F2

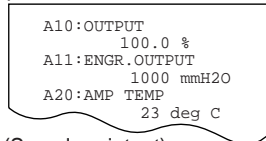

(Sample printout)

F0505.EPS

(3) PRINTING ALL PARAMETERS FROM A MENU CHOICE

①

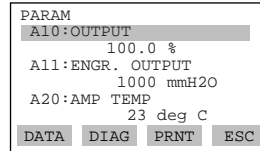

1. Press [F4] PRNT on parameter panel ① to change the function commands.

F3

②

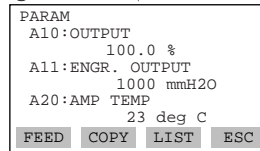

2. Press [F3] LIST on panel ② to call print panel ③.

F3

③

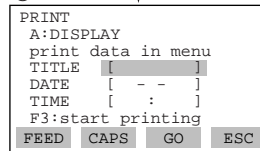

3. If you type the title, date, and time, they print out together with the input data. Enter the data into print panel ③.

(Printing can be started even if the title, date, and time are left unspecified. →press [F3] GO)

F0506-1.EPS

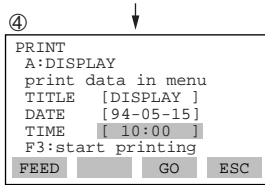

4. Press [F3] GO to start printing. Pressing [ENT] with the cursor on "TIME" will also start printing.

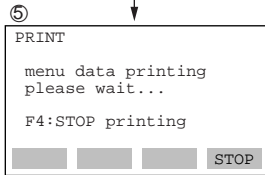

5. Panel ⑤ is displayed while printing is in progress. Press [F4] STOP until printing stops in order to cancel printing.

The message "PRINTING END" appears when the printing is complete.

F0506-2.EPS

(4) PRINTING ALL PARAMETERS

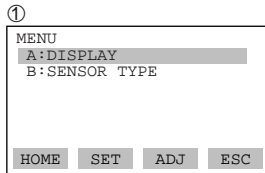

1. Connect the BT200 to the other instrument and make it ready for communication. Press [F4] ESC on the menu panel to call panel ②.



F0507-1.EPS

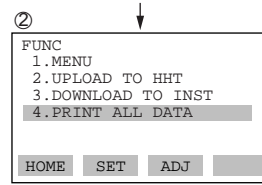

2. Select '4.PRINT ALL DATA' from command panel ② and press [ENT].

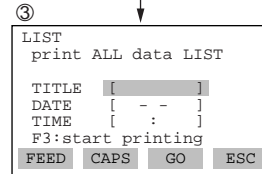

3. Type the title, date, and time, and press [F3] GO to start printing. (Printing can be started even if the title, date, and time are left unspecified.)

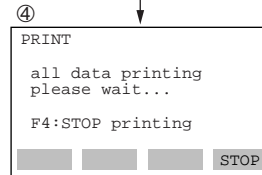

4. Panel ③ is displayed while printing is in progress. Press [F4] STOP until printing stops in order to cancel printing.

The message "PRINTING END" appears when the printing is complete.

F0507-2.EPS

(5) PRINTING UPLOADED OR DOWNLOADED DATA

a) UPLOAD

①

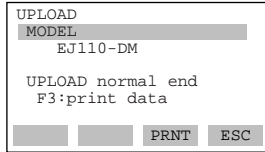

1. Panel ① appears following the completion of an upload. (refer to section 5.1(1)) Press [F3] PRNT to display panel ②.

F3

②

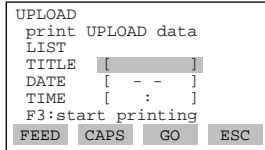

2. Type the title, date, and time, and press [F3] GO to start printing.

F3

③

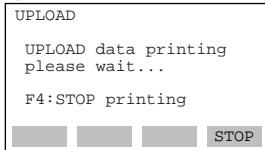

3. The message “UPLOAD data printing please wait...” is displayed while the printing is in progress. Press [F4] STOP to cancel printing.

The message “PRINTING END” appears when the printing is complete.

F0508.EPS

b) DOWNLOAD

following the end of a download, the downloaded data can be printed out by following the procedural steps similar to printing out uploaded data explained in a) UPLOAD.



NOTE

Printing of uploaded or downloaded data is executed while communicating with the connected instrument. Unplugging the cable while printing would cause a communication error to occur, canceling communication.

(6) PRINTING A LIST OF SELF-CHECK INFORMATION

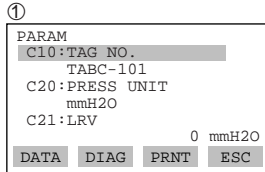

1. Press [F2] DIAG on the parameter panel to call self-check panel ① .

F2

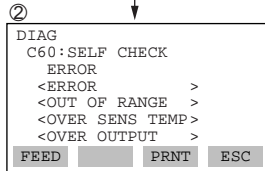

2. Press [F3] PRNT to start printing.

F3

[F1] FEED →Paper feed
 [F3] PRNT →Print out self-check information.
 [F4] ESC →Return to the parameter panel ①.

F0509.EPS

5.3 OFFLINE FUNCTIONS

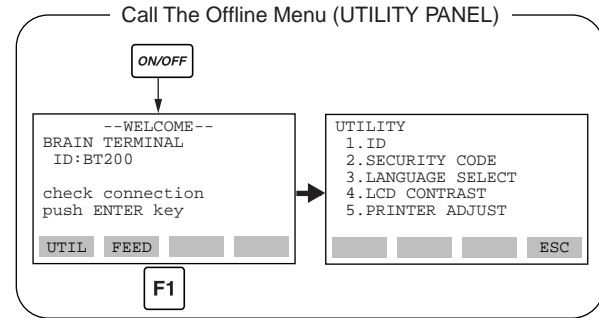

F0510.EPS

(1) ID (Identification Code) SETUP

Each BT200 BRAIN TERMINAL is assigned an ID (identification code) to identify itself from other terminals. The ID is displayed on the startup panel and the security code setup panel. You can change the ID from the utility panel. The ID is up to eight characters long.

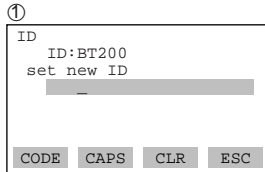

1. Select '1.ID' from the utility panel to call panel ①. Type the new ID and press [ENT] twice.

F0511.EPS

(2) LANGUAGE SELECTION (BETWEEN ENGLISH AND JAPANESE)

a) English to Japanese

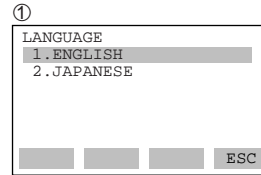

1. Select '3. LANGUAGE SELECT' from the utility panel to select the panel ①. If you Select '2. JAPANESE' and press [ENT], the message mode is switched to Japanese.

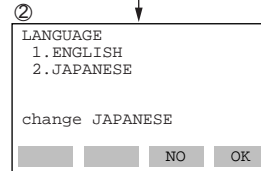

[F3] NO →Return to panel ①.
[F4] OK →Go to panel ③.

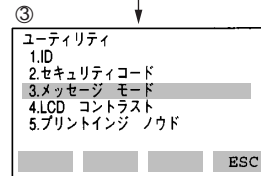

[F4] ESC →Start communication, returning to the initial data panel.

F0512.EPS

b) Japanese to English

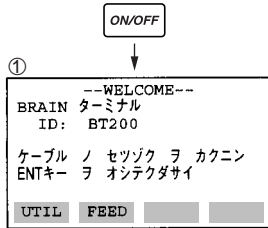

1. Press [F1] to select the utility panel ② in Japanese.

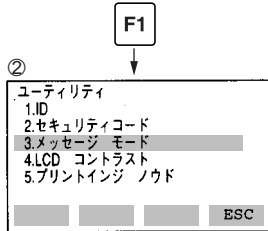

2. Select '3. メッセージ モード' and press [ENT] to go to panel ③.

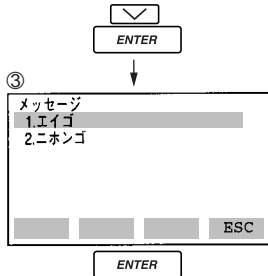

3. Select '1. エイゴ' and press [ENT] to go to panel ④ for confirmation.

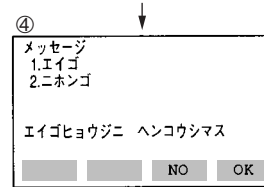

[F3] NO →Return to panel ③.
[F4] OK →Go to panel ⑤.

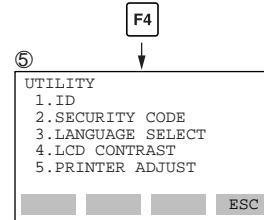

[F4] ESC →Start communication, returning to the initial data panel.

F0515-2.EPS

(3) LCD CONTRAST CONTROL

The BT200 features software capability to control the LCD contrast. There are two ways to control the LCD contrast.

a) CONTROLLING THE LCD ON THE STARTUP PANEL

While the startup panel is on display, press [<] or [>] to call the LCD contrast panel directly.

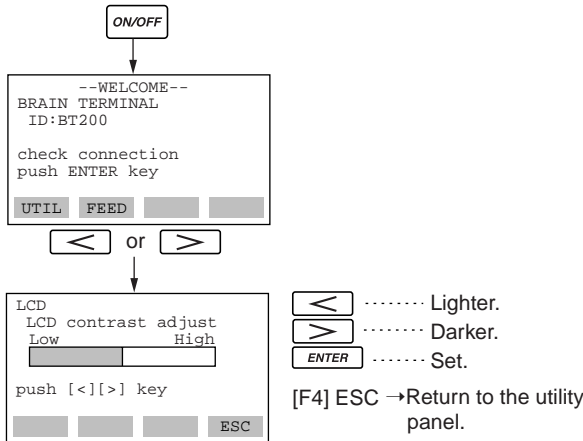

F0513.EPS

b) CONTROLLING THE LCD ON THE UTILITY PANEL

Select '4. LCD CONTRAST' from the utility panel and press [ENT] to select the LCD contrast control panel. Use [<] or [>] to control the LCD contrast. When finished, press [ENT] to set the BT200 to the specified LCD contrast level.

(4) PRINT DENSITY CONTROL

You can control the print density while printing test copies.

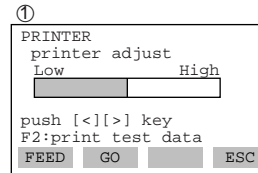

1. Select '6. PRINT DENSITY CONTROL' from the utility panel.
2. Press [F2] GO on panel 1 to start test printing. (Press [F4] STOP to cancel printing.)
3. Verify that test printout and use [<] or [>] to control the print density.

Test printout

```

! " # $ % & ' ( ) * + , - . /
0 1 2 3 4 5 6 7 8 9 : ; < = > ?
@ A B C D E F G H I J K L M N O
P Q R S T U V W X Y Z [ \ ] ^ _
` a b c d e f g h i j k l m n o
p q r s t u v w x y z { | } ~
  
```

Repeat Steps 2 and 3 to finally control the print density.

- [F1] FEED →Paper feed
- [F2] GO →Start test printing
- [F4] ESC →Return to the utility panel.

F0514.EPS

6. MAINTENANCE

6.1 REPLACING BATTERIES

When the **BATTERY** indicator is lit on the screen, it warns you of a low battery voltage.

Replace the batteries with new batteries having a specified voltage (1.5 V) as soon as possible. The BT200 could stop operating any moment if you continue to use it without replacing the batteries.

- Prerequisites : One Phillips screwdriver
- : Five new batteries (AA)
- : Dry cloth

To replace the batteries, follow these steps.

- (1) Switch off the BT200.
- (2) Using a Phillips screwdriver, remove three screws on the back of the unit and detach the battery case. Be careful not to lose the screws. (Figure 6.1.a)

- (3) Take out the old batteries and insert new batteries after cleaning the new batteries with dry cloth fully and noting their polarity. (Figure 6.1.c)
- (4) Install the battery case by fitting its connector into the unit connector. Be careful not to damage the connectors. (Figure 6.1.d)
- (5) Tighten the three screws with the Phillips screwdriver.



CAUTION

For intrinsically safe type, the battery used in BT200 must be as follows.

Manufacture	Model	Type	Voltage
DURACELL	MN1500 (PC1500)	Alkaline- manganese	1.5 V

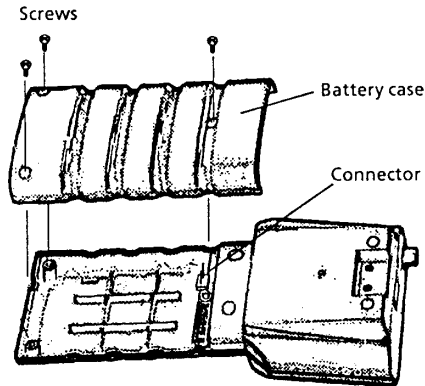

Figure 6.1.a Removing Screws

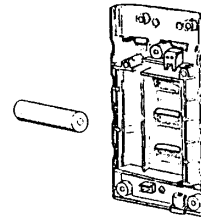

Figure 6.1.b Battery Case

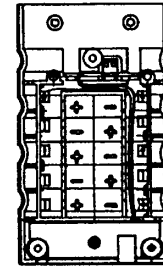

Figure 6.1.c Directions of Batteries Loaded

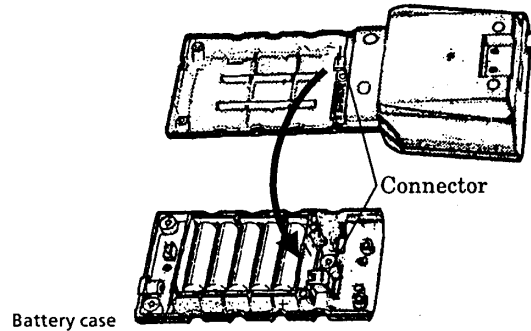

Figure 6.1.d Fitting Connector

6.2 LOADING ROLL PAPER

With the BT200-P00 BRAIN TERMINAL with a printer, follow these steps to load roll paper.

- (1) Open the cover.
- (2) Cut the end of the roll paper as shown.
- (3) Insert the cut end of the roll paper into part A. The roll paper has its face and back. Insert the roll paper to face as shown in Figure 6.2.
- (4) Push in the roll paper until its end comes out of part B.
When the roll paper comes out, pull it out by using your fingers.
- (5) Lead the roll paper through slit c in the cover and close the cover.
- (6) Switch on the BT200 and press [F2] FEED on the startup panel. Make sure that the roll paper is fed correctly.

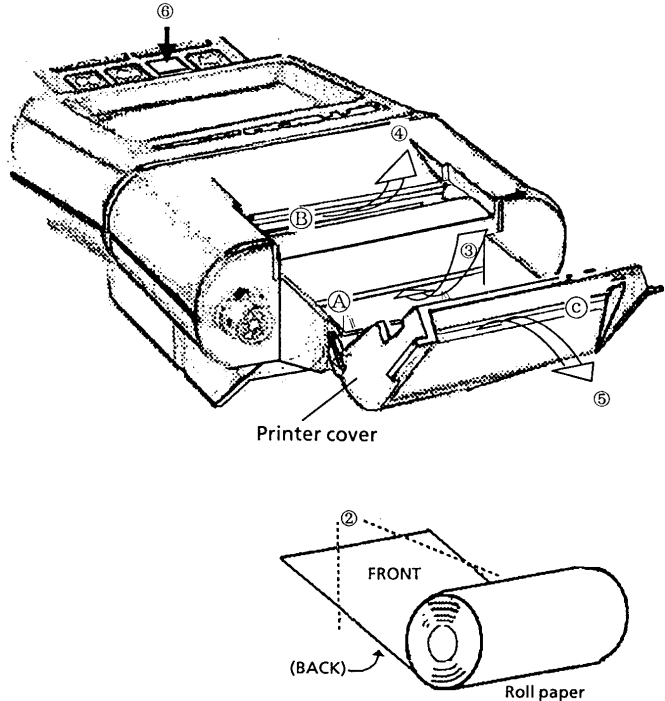
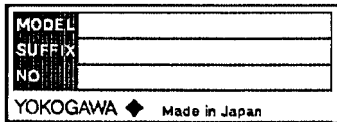

Figure 6.2 Loading Roll Paper

7. TROUBLESHOOTING

Here are simple troubleshooting tips. If problems persist after all the suggested checks, call our service for repair, with a detailed description of the following:



- (1) Model code and serial number of your unit (found on the nameplate on the back of the unit).
- (2) Model code, serial number, and control number of the connected instrument.
- (3) Wiring diagram
- (4) Details of the problem
- (5) Checks made and the results
- (6) Other related information



F0701 EPS

Figure 7.1 The Nameplate

1. PRESSING THE KEY PRODUCES NO DISPLAY

- (1) Did you press the  key positively?
Press the  key two or three times to make sure.
- (2) Did you adjust the LCD contrast properly?
Press the  key on the startup panel.
- (3) Are the batteries exhausted?
Replace with new batteries as appropriate.

2. THE DISPLAY IS ERASED AUTOMATICALLY

The autopower-off feature of the BT200 will switch it off automatically when no key access is made for five minutes or longer. Press the  key once again to restore screen.

3. THE BATTERY INDICATOR IS ON

The BATTERY indicator, when on, warns you of a low battery voltage. Replace with new batteries having a specified voltage (1.5 V) as soon as possible. The BT200 could stop operating at any moment if you continue to use it.

4. THE BT200 STOPS WITH THE COMMUN. ERROR INDICATION ON

The BT200 needs to communicate with the connected instrument in order to function. It doesn't operate by itself. This problem suggests that communication between the BT200 and the connected instrument is disabled.

- (1) Are the BT200 and the instrument wired as instructed in the relevant instruction manuals?

Check again to make sure.

- (2) Is the connected instrument switched on? Is it operable?

Check again to make sure.

- (3) Is a reception resistor of 250 ohms or higher inserted in series in the current output circuit of the connected instrument? If you are using our

distributor to power the connected instrument, a reception resistor is built in it.

- (4) Does the wiring distance of the current output cable of the connected instrument exceed 2 km(1.24 miles)? Is a capacitor in excess of 0.22 μ F inserted in parallel with the current output cable of the mating instrument?

In either case, the communication signal components are bypassed by the electrostatic capacitance, disabling communication. Check again to make sure.

- (5) Is the communication cable for the BT200 broken? If a spare cable is available, replace it. If not, use a multimeter to check for breakage with reference to the connections shown below. (Figure 7.2)

6. SELF CHK ERROR INDICATION IS ON

The SELF CHK ERROR indication, when on, suggests that a setting is out of range or a fault exists. Press [F2] DIAG on the parameter panel to check the settings. For detailed definitions of the diagnostic messages and the associated actions, refer to the user's manual for the connected instrument

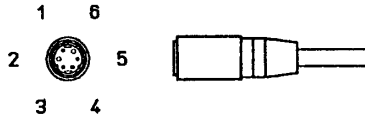

Figure 7.2 Connector pin numbers

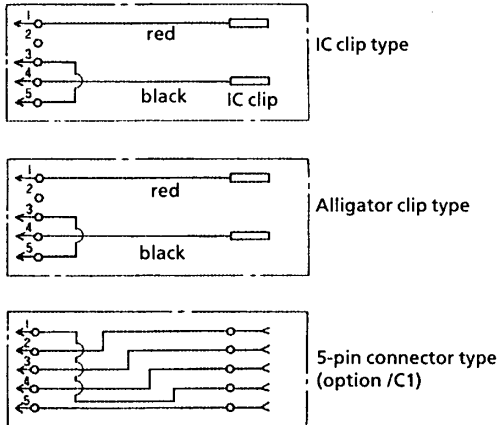

Figure 7.3 Wiring

APPENDIX A

1. Setting and Changing SECURITY CODE

The BT200 is shipped without a security code set. You can alter setup data without having to register a security code. If you set a security code, you need to type it only once during the first setup change procedure after the BT200 is switched on. The security code is a series of four digits (0 through 9).

A) SETTING A SECURITY CODE

To register a security code in the BT200 as shipped, follow these steps.

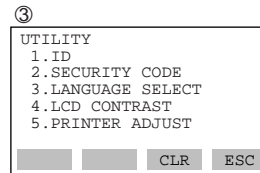
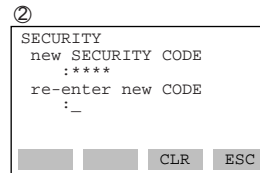
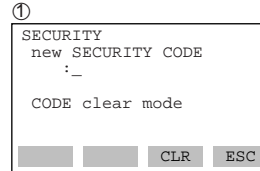

1. Select '2. SECURITY CODE' from the utility panel and press [ENT] to select the security panel ①.
2. Type a string of four digits (0 through 9) and press [ENT].
Note: The security code must be numeric and four digits long.
3. Type the security code again and press [ENT] to complete the procedure.

F0A01.EPS

B) CHANGING THE SECURITY CODE

To change a security code after it has been registered, follow these steps.

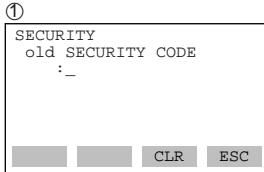

1. Select the security panel ①.

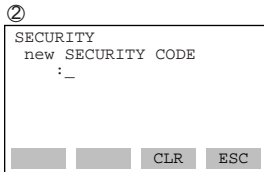

2. Type the current security code and press [ENT].

If you type a code different from the registered security code, the message “incorrect CODE” is displayed. Press [F4] ESC and retry.

3. Type a new security code and press [ENT].

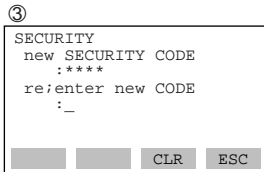

4. Type the new security code again and press [ENT] to complete the procedure.

If you type a different code, the message “incorrect CODE set CODE again” is displayed. Retry from Step 2 downward.

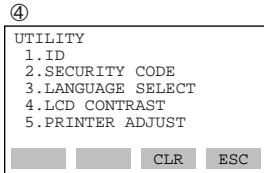

2. Canceling a SECURITY CODE

To cancel a registered security code, follow these steps.

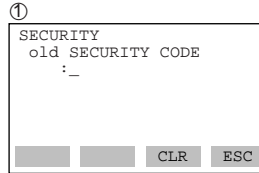

1. Select the security panel ①. Type the old current security code and press [ENT].

2. Type 'PASS' instead of a new security code.

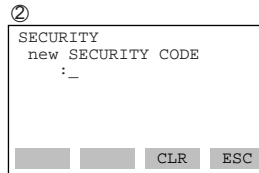

3. The message “CODE clear mode” is displayed.

4. Press [F4] ESC to complete the procedure.

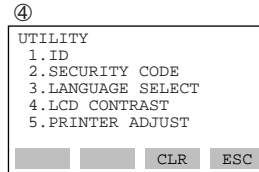
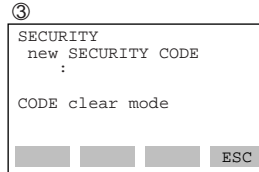

3. When You Forget the SECURITY CODE

When you forget the security code that has been registered and register a new security code from the beginning, follow these steps.

①

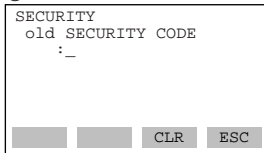

1. Call security panel ① and type 'RSET'.

2. Type a new security code and press [ENT].

②

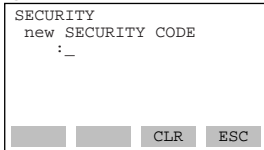

3. Type the new security code again and press [ENT] to complete the procedure.

4. Press [F4] ESC to complete the procedure.

③

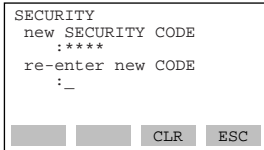

④

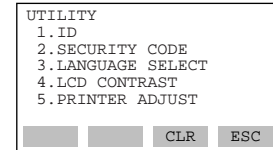

F0A04.EPS

APPENDIX B

Installation of CS Intrinsically Safe Type

BT200 BRAIN TERMINAL (Model BT200-N00/CS1) is applicable for use in hazardous locations;

- Intrinsically Safe for Class I, Division 1, Groups A, B, C & D Hazardous Locations.
- Temperature Class: T4
- Ambient Temperature: -15 to 55°C

Electrical Parameters

- BT200 Intrinsically Safe Apparatus Parameters
 - The Maximum Input Voltage $V_{max(in)}=30V$
 - The Maximum Input Current $I_{max(in)}=165mA$
 - The Maximum Input Power $P_{max(in)}=0.9W$
 - The Maximum Internal Capacitance $C_i=0$
 - The Maximum Internal Inductance $L_i=730\mu H$

- The Maximum Output Voltage $V_{max(out)}=2V$
- The Maximum Output Current $I_{max(out)}=22mA$
- The Maximum Output Power $P_{max(out)}=11mW$
- The Maximum Allowed Capacitance $C_a=3000\mu F$
- The Maximum Allowed Inductance $L_a=30mH$

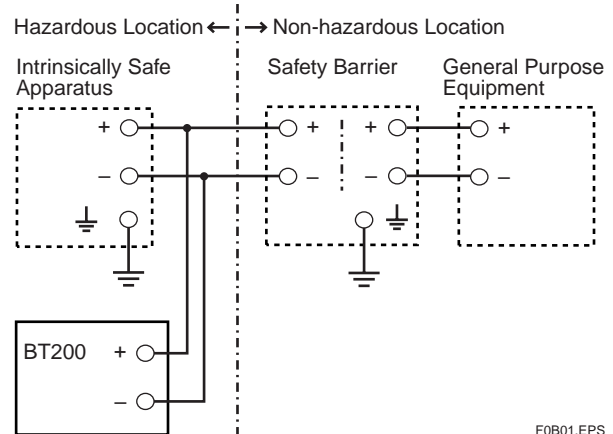

FOB01.EPS

- Safety Barriers Parameters (CSA Certified Barriers)
 $V_{oc} \leq 28V$
 $I_{sc} \leq 143mA$
 $P_{max} \leq 889mW$
- Intrinsically Safe Apparatus Connected with BT200 (CSA Certified Apparatus)
 $V_{max} \geq (V_{oc} \text{ of Safety Barrier}) + 2V$
 $I_{max} \geq (I_{sc} \text{ of Safety Barrier}) + 22mA$
 $P_{max} \geq (P_{max} \text{ of Safety Barrier}) + 11mW$

Installation

- All wiring shall comply with Canadian Electrical code Part I and Local Electrical Codes.
- General purpose equipment connected to barrier must not use or not generate more than 250 Vrms or Vdc.
- The safety barriers and intrinsically safe apparatus connected with BT200 must be certified by CSA.

- Associated apparatus manufacturer’s installation drawing must be followed when installing these intrinsically safe apparatuses.
- Not a warning label worded: “SUBSTITUTION OF COMPONENTS MAY IMPAIR INTRINSIC SAFETY” and “TO PREVENT IGNITION OF A HAZARDOUS ATMOSPHERE, BATTERIES MUST ONLY BE CHANGED IN AN AREA KNOWN TO BE NONHAZARDOUS” and “USE IN ACCORDANCE WITH INSTRUCTION MANUAL IM 1C0A11-01E”.

- The battery used in BT200 must be as follows.

Manufacture	Model	Type	Voltage
DURACELL	MN1500 (PC1500)	Alkaline- manganese	1.5 V

- The instrument modification or parts replacement by other than authorized representative of Yokogawa Electric Corporation and Johnson Yokogawa Corporation is prohibited and will void Canadian Standard Association Intrinsic Safety Certification.

REVISION RECORD

Title: Model BT200 BRAIN TERMINAL

Manual No.: IM 01C00A11-01E

Edition	Date	Page	Revised Item
1st	1994 May	—	New Publication
2nd	1996 April	CONTENTS	· Add Subsection 1.2(4) 'CAUTION FOR INTRINSICALLY SAFE TYPE', Subsection 1.2(5) 'EMC Conformity Standards' and Appendix B.
		1-2	· Add description 'e' (Subsection 1.2(2))
		1-3	· Add description for printing (Subsection 1.2(3)a)
			· Add Subsection 1.2(4) 'CAUTION for INTRINSICALLY SAFE TYPE'
		1-4	· Add Subsection 1.2(5) 'EMC CONFORMITY STANDARDS'
		2-4	· Add optional code /CS1. (Subsection 2.2)
		4-4	· Error correction (FUNCTION COMMAND LIST)
		6-1	· Add 'CAUTION' FOR INTRINSICALLY SAFE TYPE (Subsection 6.1)
	Appendix	· Add Appendix B 'Installation of CSA Intrinsically Safe type'.	

Edition	Date	Page	Revised Item
3rd	2002 July	—	Revised a book in a new format. · Delete 'EMC CONFORMITY STANDARDS' table. · Add CE and C-tick markings.

Rev1.EPS