

# General Specifications

## Model YTA110 Temperature Transmitter

YTA SERIES

GS 01C50B01-00E

[Style: S3]

The YTA110 is the high performance temperature transmitter that accepts Thermocouple, RTD, ohms or DC millivolts inputs and converts it to a 4 to 20 mA DC signal for transmission. The YTA110 supports either BRAIN or HART communication protocol.

The YTA110 in its standard configuration is certified by TÜV as complying with SIL2 for safety requirement.



### ■ FEATURES

#### High performance

Microprocessor-based sensing technology ensures long-term accuracy and high reliability.

#### High reliability

Dual-compartment housing realizes high resistance capability to harsh environments, and YTA110 has SIL2 capability for safety requirement.

#### Variety of sensor inputs

The type of sensor input is user-selectable from thermocouples (T/C), RTDs, ohms, or DC millivolts.

#### Digital communication

BRAIN or HART® communication protocol is available. The instrument configuration can be changed by the user with using the BT200 or HART communicator.

#### Self-diagnostics function

Continuous self-diagnostics capability ensures long-term performance and lower cost of ownership.

#### LCD display with bargraph

The LCD display provides both a digital readout and percent bargraph simultaneously.

### ■ STANDARD SPECIFICATIONS

#### □ PERFORMANCE SPECIFICATIONS

##### Accuracy

(A/D accuracy/span + D/A accuracy) or  $\pm 0.1\%$  of calibrated span, whichever is greater. See Table 1. on page 3.

##### Cold Junction Compensation Accuracy

(For T/C only)  
 $\pm 0.5^\circ\text{C}$  ( $\pm 0.9^\circ\text{F}$ )

##### Ambient Temperature Effect (per $10^\circ\text{C}$ change)

$\pm 0.1\%$  or  $\pm$  (Temperature Coefficient /span), whichever is greater. See Table 2. for Temperature Coefficient.

##### Stability

RTD:  
 $\pm 0.1\%$  of reading or  $\pm 0.1^\circ\text{C}$  per 2 years, whichever is greater at  $23\pm 2^\circ\text{C}$ .

##### T/C:

$\pm 0.1\%$  of reading or  $\pm 0.1^\circ\text{C}$  per year, whichever is greater at  $23\pm 2^\circ\text{C}$ .

#### 5 Year Stability

##### RTD:

$\pm 0.2\%$  of reading or  $\pm 0.2^\circ\text{C}$ , whichever is greater at  $23\pm 2^\circ\text{C}$ .

##### T/sC:

$\pm 0.4\%$  of reading or  $\pm 0.4^\circ\text{C}$ , whichever is greater at  $23\pm 2^\circ\text{C}$ .

#### RFI Effect

Tested per EN 50082-2, field intensity up to 10 V/m.

#### Power Supply Effect

$\pm 0.005\%$  of calibration span per volt

#### Vibration Effect

10 to 60 Hz 0.21 mm peak displacement  
60 to 2000 Hz 3G

#### Position Effect

None

#### □ FUNCTIONAL SPECIFICATIONS

#### Input

Input type is selectable: Thermocouples, 2-, 3-, and 4-wire RTDs, ohms and DC millivolts. See Table 1. on page 3.

#### Span & Range Limits

See Table 1. on page 3.

#### Input signal source resistance (for T/C, mV)

1 k $\Omega$  or lower

#### Input lead wire resistance (for RTD, ohm)

10  $\Omega$  per wire or lower

#### Output

Two wire 4 to 20 mA DC. Output range: 3.68 mA to 20.8 mA

BRAIN or HART® protocol is superimposed on the 4 to 20 mA signal.

Any single value from the followings can be selected as the analog output signal.

Sensor 1, Terminal Temperature.

Also, up to three of the above values can be displayed on LCD display or read via communication.

#### Isolation

Input/Output/GND isolated to 500 V DC

**Sensor Burnout**

High (21.6 mA DC) or Low (3.6 mA DC), userselectable.

**Output in Transmitter Failure**

Up-scale: 110%, 21.6 mA DC or more (Standard or Optional code /C3)  
Down-scale: -5%, 3.2 mA DC or less (Optional code /C1 or /C2)

**Update Time**

Approximately 0.5 seconds

**Turn-on Time**

Approximately 5 seconds

**Damping Time Constant**

Selectable from 0 to 99 seconds

**Ambient Temperature Limits**

Option code may affect limits.  
-40 to 85 °C (-40 to 185 °F)  
-30 to 80 °C (-22 to 176 °F) with Integral Indicator

**Ambient Humidity Limits**

5 to 100 % RH at 40 °C (104 °F)

**EMC Conformity Standards**  ,  N200

EN61326, AS/NZS CISPR11

**SIL Certification**

YTA110 temperature transmitter is certified by TÜV NORD CERT GmbH in compliance with the following standards;  
IEC 61508: 2000; Part1 to Part 7 Functional Safety of Electrical/electronic/programmable electronic related systems;  
SIL 2 capability for single transmitter use, SIL 3 capability for dual transmitter use.

**Self-calibration**

The analog-to-digital measurement circuitry automatically self-calibrates for temperature update by comparing the dynamic measurement to extremely stable and accurate internal reference elements.

**Self-diagnostics**

Loss of input error, ambient temperature error, EEPROM error, and CPU error. Up to four error history can be stored in the memory.

**Manual Output Function**

The output value can be set manually.

**Supply & Load Requirements**

**Supply Voltage**

10.5 to 42 V DC for general use and flameproof type  
10.5 to 32 CV DC for lightning protector (Optional code /A)  
10.5 to 30 V DC for intrinsically safe, Type n, nonincendive, or non-sparking type  
Minimum voltage limited at 16.4 V DC for digital communications, BRAIN and HART® protocols

**Load**

0 to 1335 Ω for operation  
250 to 600 Ω for digital communication  
See Figure 1. on page 4.

**Communication Requirements**

**BRAIN:**

**Communication Distance**

Up to 2 km (1.25 miles) when using CEV polyethylene-insulated PVC-sheathed cables. Communication distance varies depending on type of cable used.

**Load Capacitance**

0.22 μF or less

**Load Inductance**

3.3 mH or less

**Input Impedance of communicating device**

10 kΩ or more at 2.4 kHz.

**PHYSICAL SPECIFICATIONS**

**Enclosure**

**Material**

Low copper cast-aluminum alloy

**Coating**

Polyurethan resin baked finish  
Color: Deep-sea moss green (Munsell 0.6GY3.1/2.0)

**Degrees of Protection**

IP67, NEMA4X, JIS C0920 immersion proof

**Data and tag plate**

SUS304 Stainless steel

**Mounting**

Optional mounting brackets can be used either for two-inch pipe or flat panel mounting.

**Terminal Screws**

M4 screws

**Integral Indicator**

Optional LCD digital indicator includes 5-digit numerical display with °C, K, °F, °R, % and mV, 0 to 100 % bargraph and dot-matrix display.

**Weight**

1.2 kg(2.6 lb) without Integral indicator and Mounting bracket. Integral indicator weights 0.2 kg(0.4 lb).

**Electrical Connections**

Refer to 'MODEL AND SUFFIX CODES' on page 5.

**Table 1. Sensor type, measurement range, and accuracy.**

Sensor Type	Reference Standard	Measurement Range		Minimum Span (Recommended)	Accuracy				D/A Accuracy	
		°C	°F		Input range		A/D Accuracy			
					°C	°F	°C	°F		
T/C	IEC584	100 to 1820	212 to 3308	25 °C (45 °F)	100 to 300	212 to 572	± 3.0	± 5.4	± 0.02% of span	
					300 to 400	572 to 752	± 1.0	± 1.8		
					400 to 1820	752 to 3308	± 0.75	± 1.35		
		-200 to 1000	-328 to 1832		-200 to -50	-328 to -58	± 0.35	± 0.63		
					-50 to 1000	-58 to 1832	± 0.16	± 0.29		
		-200 to 1200	-328 to 2192		-200 to -50	-328 to -58	± 0.40	± 0.72		
					-50 to 1200	-58 to 2192	± 0.20	± 0.36		
		-200 to 1372	-328 to 2502		-200 to -50	-328 to -58	± 0.50	± 0.90		
	-50 to 1372				-58 to 2502	± 0.25	± 0.45			
	-200 to 1300	-328 to 2372	-200 to -50		-328 to -58	± 0.80	± 1.44			
			-50 to 1300		-58 to 2372	± 0.35	± 0.63			
	R	ASTM E988	-50 to 1768		-58 to 3214	-50 to 0	-58 to 32	± 1.0		± 1.8
						0 to 100	32 to 212	± 0.80		± 1.44
			100 to 600		212 to 1112	100 to 600	212 to 1112	± 0.60		± 1.08
600 to 1768				1112 to 3214		± 0.40	± 0.72			
S	DIN43710	-50 to 1768	-58 to 3214	-50 to 0	-58 to 32	± 1.0	± 1.8			
				0 to 100	32 to 212	± 0.80	± 1.44			
T	ASTM E988	-200 to 400	-328 to 752	-200 to -50	-328 to -58	± 0.25	± 0.45			
				-50 to 400	-58 to 752	± 0.14	± 0.25			
W3	ASTM E988	0 to 2300	32 to 4172	0 to 400	32 to 752	± 0.80	± 1.44			
				400 to 1400	752 to 2552	± 0.50	± 0.90			
				1400 to 2000	2552 to 3632	± 0.60	± 1.08			
				2000 to 2300	3632 to 4172	± 0.90	± 1.62			
				0 to 400	32 to 752	± 0.70	± 1.26			
				400 to 1400	752 to 2552	± 0.50	± 0.90			
W5	DIN43710	0 to 2300	32 to 4172	1400 to 2000	2552 to 3632	± 0.70	± 1.26			
				2000 to 2300	3632 to 4172	± 0.90	± 1.62			
				-200 to -50	-328 to -58	± 0.30	± 0.54			
				-50 to 900	-58 to 1652	± 0.20	± 0.36			
L	DIN43710	-200 to 900	-328 to 1652	-200 to -50	-328 to -58	± 0.50	± 0.90			
				-50 to 600	-328 to 1112	± 0.25	± 0.45			
RTD	IEC751	-200 to 850	-328 to 1562	-200 to 850	-328 to 1562	± 0.14	± 0.25			
				-200 to 850	-328 to 1562	± 0.30	± 0.54			
				-200 to 850	-328 to 1562	± 0.20	± 0.36			
				-200 to 850	-328 to 1562	± 0.16	± 0.29			
	Cu	SAMA RC21-4	-70 to 150	-94 to 302	-70 to -40	-94 to -40	± 1.35	± 2.43		
					-40 to 150	-40 to 302	± 1.0	± 1.8		
	Ni120	—	-70 to 320	-94 to 608	-70 to 320	-94 to 608	± 0.11	± 0.19		
mV	—	-10 to 100 [mV]		3 [mV]	—		± 12 [μV]			
ohm	—	0 to 2000 [Ω]		20 [Ω]	—		± 0.35 [Ω]			

T01E.EPS

Total Accuracy = (A/D Accuracy / Span + D/A Accuracy) or (± 0.1% of calibrated span), whichever is greater.

For T/C input, add Cold Junction Compensation Accuracy (± 0.5 °C) to the total accuracy.

Example; when selecting Pt100 with measurement range of 0 to 200 °C.

$$\frac{0.14^{\circ}\text{C}}{200^{\circ}\text{C}} \times 100\% \text{ of span} + 0.02\% \text{ of span} = 0.09\% \text{ of span}$$

Since the value is smaller than ± 0.1% of span, the total accuracy is ± 0.1%.

**Table 2. Temperature Coefficient**

Sensor Type		Temperature Coefficient
Thermocouples E,J,K,N,T,L,U		0.08°C + 0.02% of abs.reading
Thermocouples R,S,W3,W5		0.25°C + 0.02% of abs.reading
T/C B	100°C ≤ Reading < 300°C	1°C + 0.02% of abs.reading
	300°C ≤ Reading	0.5°C + 0.02% of abs.reading
RTD		0.08°C + 0.02% of abs.reading
mV		0.002 mV + 0.02% of abs.reading
ohm		0.1 Ω + 0.02% of abs.reading

T02E.EPS

Note1: Ambient Temperature Effect per 10°C change is ±0.1% or ±(temperature coefficient/span), whichever is greater.

Note2: The “abs.reading” on Table2 means the absolute value of the reading in °C.

Example of abs reading;

When the temperature value is 250 Kelvin, abs reading is 23.15, absolute (250–273.15).

Example of Ambient Temperature Effect;

Conditions;

- 1) Input Sensor: Pt100
- 2) Calibration Range: –100 to 100°C
- 3) Reading value: –50°C

Ambient Temperature Effect per 10°C;

$$\text{Temperature Coefficient/Span} = (0.08^\circ\text{C} + 0.02/100 \times |-50^\circ\text{C}|) / \{100^\circ\text{C} - (-100^\circ\text{C})\} = 0.00045 \rightarrow 0.045\%$$

Therefore, Ambient Temperature Effect is ±0.1%/10°C

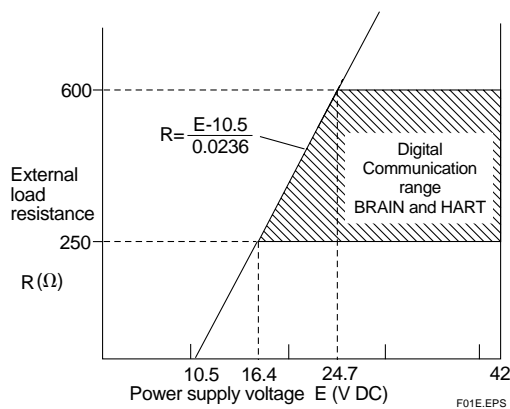

**Figure 1. Relationship Between Power Supply Voltage and External Load Resistance.**

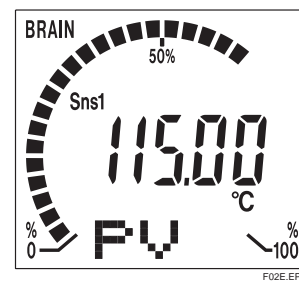

**Figure 2. Integral Indicator Display Example.**

## MODEL AND SUFFIX CODES

Model	Suffix Codes	Descriptions
<b>YTA110</b>	.....	Temperature Transmitter
Output Signal	<b>-D</b> .....	4 to 20mA DC with digital communication (BRAIN protocol)
	<b>-E</b> .....	4 to 20mA DC with digital communication (HART protocol, refer to GS 01C50T01-00E)
—	<b>A</b> .....	Always A
Electrical Connection	<b>0</b> .....	G1/2 female
	<b>2</b> .....	1/2 NPT female
	<b>3</b> .....	Pg 13.5 female
	<b>4</b> .....	M20 female
Integral Indicator	<b>D</b> .....	with digital indicator
	<b>N</b> .....	None
Mounting Bracket	<b>B</b> ....	SUS304 Stainless steel 2-inch horizontal pipe mounting *1
	<b>D</b> ....	SUS304 Stainless steel 2-inch vertical pipe mounting *1
	<b>N</b> ....	None
Optional Codes	/ <input type="checkbox"/> Optional Specifications	

\*1: For flat-panel mounting, please prepare bolts and nuts.

T03E.EPS

## OPTIONAL SPECIFICATIONS

Item	Descriptions	Code		
Lightning protector	Power supply voltage: 10.5 to 32 V DC Allowable current: Max. 6000A(1×40μs), repeating 1000A(1×40μs) 100 times	<b>A</b>		
Painting	Coating change	Epoxy resin coating	<b>X1</b>	
	Color change	Amplifier cover only	Munsell code: N1.5 Black	<b>P1</b>
			Munsell code: 7.5BG4/1.5, Jade green	<b>P2</b>
		Amplifier and terminal Covers	Munsell code: 7.5 R4/14 Red	<b>P7</b>
Calibration Unit	Degree F/Degree R unit	<b>PR</b>		
Output signal low-side in Transmitter failure	Output signal low-side: -5%, 3.2 mA DC or less. Sensor burnout is also set to 'LOW': -2.5%, 3.6 mA DC.	<b>D2</b>		
NAMUR NE43 Compliant	Output signal limits: 3.8 mA to 20.5 mA	Failure alarm down-scale: output status at CPU failure and hardware error is -5%, 3.2 mA or less. Sensor burnout is also set to LOW: -2.5%, 3.6 mA DC.	<b>C1</b>	
		Failure alarm up-scale: output status at CPU failure and hardware error is 110%, 21.6 mA or more. In this case Sensor burnout is High: 110%, 21.6 mA DC.	<b>C2</b>	
Data Configuration	Description into "Descriptor" parameter of HART protocol (max. 16 characters)	<b>C3</b>		
Stainless steel housing *1	Housing Material: SCS14A stainless steel (equivalent to SUS316 cast stainless steel and ASTM CF-8M)	<b>CA</b>		
		<b>E1</b>		

\*1: Not applicable for optional code JF3, G11, G12, P1, P2, P7, PR, and X1.

T04E.EPS

**OPTIONAL SPECIFICATIONS (For Explosion Protected Types)**

Item	Descriptions	Code
CENELEC ATEX (KEMA)	<p>CENELEC ATEX (KEMA) Intrinsically safe, Flameproof approval and Type n combination [Intrinsically safe approval]                      Applicable standard: EN 50014, EN 50020, EN 50284 Certificate: KEMA 02ATEX1026X                      II 1G EEx ia IIC T4,T5 Ambient Temperature: -40 to 70°C for T4, -40 to 50°C for T5                      Supply/Output circuit: Ui=30V, Ii=165mA, Pi=900mW, Ci=20nF, Li=660µH                      Input circuit: Uo=8.6V, Io=30mA, Po=70mW, Co=3µF, Lo=20mH                      Electrical Connection: 1/2 NPT female and M20 female*1</p> <p>[Flameproof and Dust Ignition Proof Approval]                      Applicable Standard: EN 60079-0, IEC 60079-1, EN 61241-0, EN 61241-1                      Certificate: KEMA 07ATEX0130                      II 2G Ex d IIC T6/T5, II 2D Ex tD A21 IP67 T70°C, T90°C                      Ambient Temperature for Gas Atmospheres: -40 to 75°C for T6, -40 to 80°C for T5                      Ambient Temperature for Dust Atmospheres: -40 to 65°C for T70°C, -40 to 80°C for T90°C                      Enclosure: IP67                      Electrical Connection: 1/2 NPT female and M20 female*1</p> <p>[Type n approval]                      Applicable standard: EN60079-15 Referential standard: IEC60079-0, IEC60079-11                      II 3G EEx nL IIC T4, T5 Ambient Temperature: -40 to 70°C for T4, -40 to 50°C for T5                      Supply/Output circuit: Ui=30V, Ci=20nF, Li=660µH                      Input circuit: Uo=8.6V, Io=30mA, Po=70mW, Co=3µF, Lo=20mH                      Electrical Connection: 1/2 NPT female and M20 female*1</p>	KU2
Canadian Standards Association (CSA)	<p>CSA Intrinsically safe, non-incendive and Explosionproof approval combination [Intrinsically safe/non-incendive approval]                      Applicable standard: C22.2 No0, C22.2 No0.4, C22.2 No25, C22.2 No94, C22.2 No142, C22.2 No157, C22.2 No213 Certificate: 172608-0001053837                      Intrinsically safe for Class I, Division 1, Groups A, B, C and D; Class II, Division 1, Groups E, F and G; Class III, Division 1:                      Non-incendive for Class I, Division 2, Groups A, B, C and D; Class II, Division 2, Groups E, F and G; Class III, Division 1:                      Enclosure Type 4X Temperature Class: T4, Ambient Temperature: -40 to 60°C,                      Supply: Vmax=30V, Imax=165mA, Pmax=0.9W, Ci=18nF, Li=730µH                      Sensor input: Voc=9V, Isc=40mA, Po=0.09W, Ca=1µF, La=10mH                      Electrical Connection: 1/2 NPT female*1</p> <p>[Explosionproof approval]                      Applicable standard: C22.2 No0, C22.2 No0.4, C22.2 No25, C22.2 No30, C22.2 No94, C22.2 No142, C22.2 No157, C22.2 No213, C22.2 No1010.1 Certificate: 1089576                      Explosionproof Class I, Div.1, Groups B, C and D, Class II, Groups E, F and G, Class III.                      For Class I, Div.2 Locations "FACTORY SEALED, CONDUIT SEAL NOT REQUIRED"                      Enclosure Type 4X Temperature Class: T6 Ambient Temperature: -40 to 60°C                      Electrical Connection: 1/2 NPT female*2</p>	CU1
Factory Mutual (FM)	<p>FM Intrinsically safe, non-incendive and Explosionproof approval combination [Intrinsically safe/non-incendive approval]                      Applicable standard: FM 3600, FM 3610, FM 3611, FM 3810                      Intrinsically safe for Class I, II, III Division 1 Groups A, B, C, D, E, F and G.                      Non-incendive for Class I, II, Division 2 Groups A, B, C, D, F and G Class III, Division 1.                      Enclosure Type: 4X Temperature Class: T4 Ambient Temperature: -40 to 60°C (-40 to 140°F)                      Supply: Vmax=30V, Imax=165mA, Pmax=0.9W, Ci=18nF, Li=730µH                      Sensor: Voc=9V, Isc=40mA, Po=90mW, Ca=1µF, La=10mH</p> <p>[Explosionproof approval]                      Applicable standard: FM 3600, FM 3615, FM 3810, NEMA250                      Class I, Division 1, Groups A, B, C and D;                      Dust-ignitionproof for Class II/III, Division 1, Groups E, F and G.                      "FACTORY SEALED, CONDUIT SEAL NOT REQUIRED." Enclosure Ratings: NEMA4X                      Temperature Class: T6 Ambient Temperature: -40 to 60°C (-40 to 140°F)                      Electrical Connection: 1/2NPT female*2</p>	FU1
	<p>FM Explosionproof approval                      Applicable standard: FM 3600, FM 3615, FM 3810, NEMA250                      Explosionproof Class I, Division 1, Groups A, B, C and D;                      Dust-ignitionproof for Class II/III, Division 1, Groups E, F and G.                      "FACTORY SEALED, CONDUIT SEAL NOT REQUIRED." Enclosure Rating: NEMA 4X                      Temperature Class: T6 Ambient Temperature: -40 to 60°C (-40 to 140°F)                      Electrical Connection: 1/2 NPT female*2</p>	FF1

\*1 : Applicable for Electrical Connection Code 2 and 4.

\*2 : Applicable for Electrical Connection Code 2.

T05E-1.EPS

Item	Descriptions	Code
Standards Association of Australia (SAA)	SAA Intrinsically safe, non-sparking and Flameproof approval combination [Intrinsically safe and non-sparking] Applicable standard: AS2380.1, AS2380.7, AS2380.9 Certificate: AUS Ex 3652X Ex ia IIC T4 (Tamb=70°C) IP66/67, Ex n IIC T4 (Tamb=70°C), IP66/67 Input parameters: Ui=30V, Ii=165mA, Pi=0.9W Output parameters: Uo=8.6V, Io=30mA, Po=62mW, Co=1μF [Flameproof approval] Applicable standard: AS2380.1, AS2380.2 Certificate: AUS Ex 3640 Ex d IIC T6 (Tamb=75°C) IP66/67 Electrical connection: 1/2 NPT female, Pg13.5 female and M20 female*4	SU1
Japanese Industrial Standards (TIIS)	TIIS Flameproof approval Ex ds IIC T6 X                      Amb. Temp.: -20 to 60°C	JF3
Attached flameproof packing adapter*3	Electrical connection: G1/2 female	1 pc.
	Applicable cable: O.D. 8.5 to 11 mm	2 pc.
IECEx Scheme*5	IECEx Flameproof and Dust ignition proof Approval Applicable Standard: IEC 60079-0, IEC 60079-1, IEC 61241-0, IEC 61241-1 Certificate: IECEx KEM 07.0044 Ex d IIC T6/T5, Ex tD A21 IP67 T70°C, T90°C Ambient Temperature for Gas Atmospheres: -40 to 75°C (-40 to 167°F) for T6, -40 to 80°C (-40 to 176°F) for T5 Ambient Temperature for Dust Atmospheres: -40 to 65°C (-40 to 149°F) for T70°C, -40 to 80°C (-40 to 176°F) for T90°C Enclosure: IP67 Electrical Connection: 1/2 NPT female and M20 female	SF2

T05E-2.EPS

\*3 : If cable wiring is to be used to a TIIS flameproof type transmitter, do not fail to add the YOKOGAWA-assured flameproof packing adapter.

\*4 : Applicable for Electrical connection code 2, 3 and 4.

\*5 : Applicable only for Australia, New Zealand area.

## DIMENSIONS

Unit: mm (Approx. inch)

### ● 2-inch horizontal pipe mounting

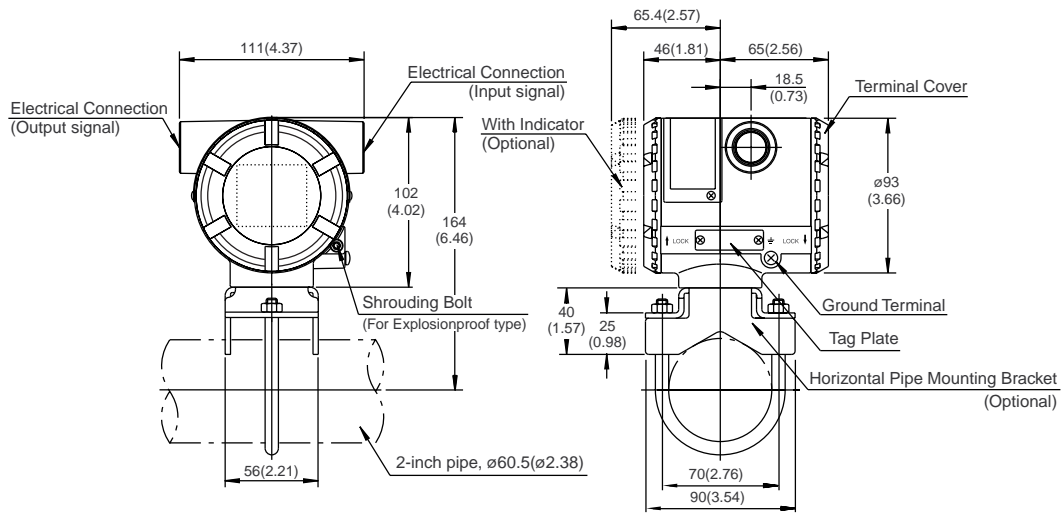

### ● 2-inch vertical pipe mounting

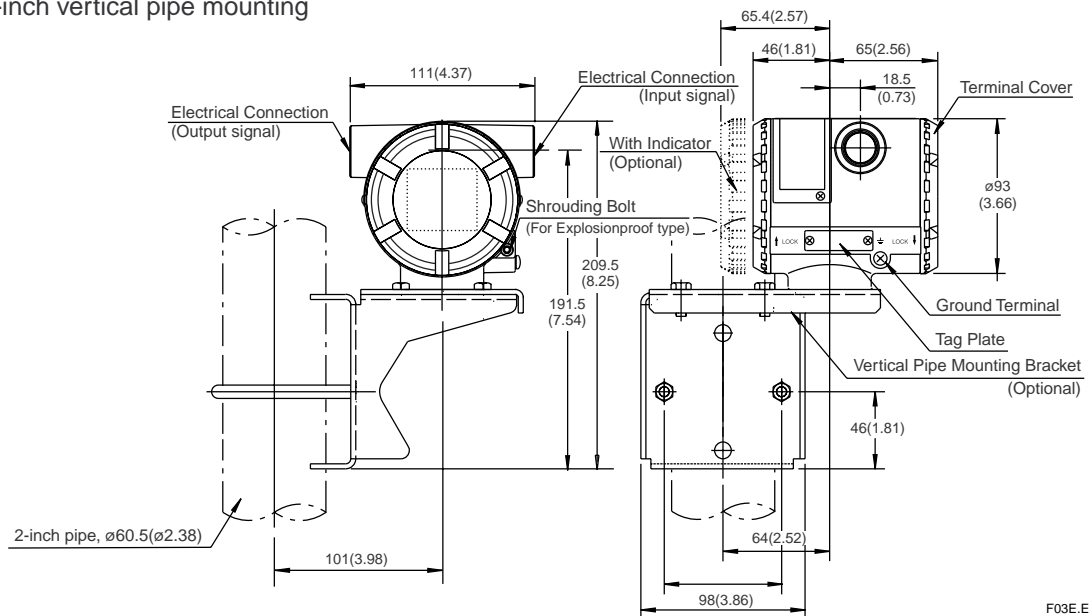

F03E.EPS

**Terminals**

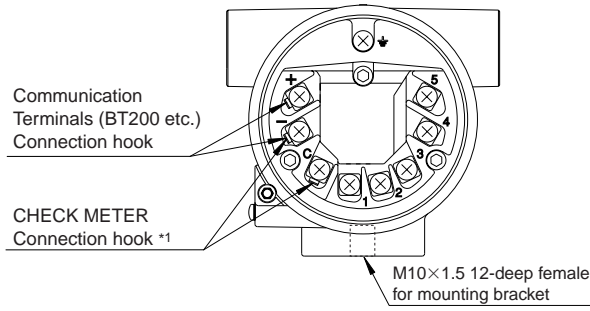

**Terminal Configuration**

+	Power Supply and output terminal
-	
C	External Indicator (ammeter) terminal *1
⏏	Ground terminal

\*1: When using an external indicator or check meter, the internal resistance must be 10Ω or less. This hook is not available for Fieldbus communication type(output signal code F).

F04.EPS

**Input Wiring**

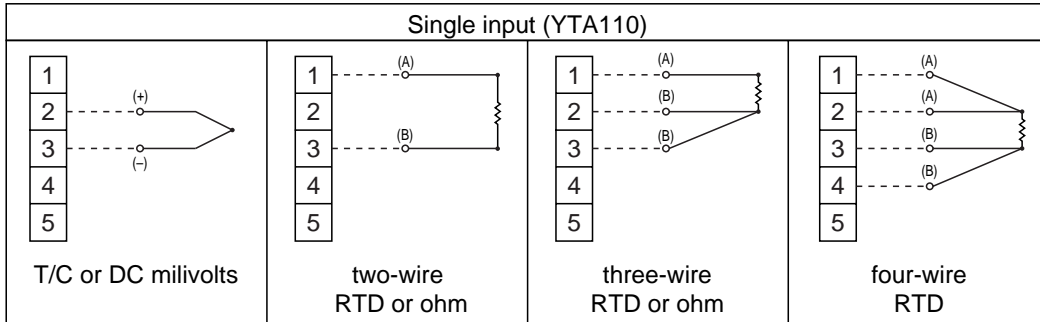

F05E.EPS

**< Ordering Information >**

Specify the following when ordering

Model, suffix codes, and optional codes

The instrument is shipped with the settings shown in Table A. Specify the following when necessary.

- Sensor type.  
For RTD and resistance input, specify the number of wire as well.  
(Example; Pt200 3-wire system)
- Calibration range and unit
  - Calibration range can be specified within the measurement range shown in Table 1. on page 3.
  - Specify one range from °C, K, °F or °R for temperature input. °F and °R are available when Optional code D2 is specified. It is not necessary to specify the unit of mV and ohm inputs, for these units automatically will be mV or Ω.
- Tag Number
- Other Items related with options  
/CA option allows specifying the setting Descriptor for HART protocol type at factory.  
Specify upto 16 characters to be entered in the Descriptor parameter.

**Table A. Settings upon shipment.**

Input sensor type	Pt100 three-wire system, or as specified
Calibration range lower limit	"0" or as specified
Calibration range upper limit	"100" or as specified
Calibration unit	"°C" or as specified
Damping time constant	2 seconds
Sensor burnout *1	High (110%, 21.6 mA DC)
Output in Transmitter failure *1	High (110%, 21.6 mA DC or more)
Integral Indicator *2	PV
Output type	Sensor 1
Tag number	As specified in order

\*1: Except when Optional code C1 or C2 is specified.

\*2: When Integral indicator is specified.

T07E.EPS

**< Related Instruments >**

Power Distributor: Refer to GS 01B04T01-02E or GS 01B04T02-00E

BRAIN TERMINAL: Refer to GS 01C00A11-00E

**< Reference >**

HART; Trademark of The HART Communication Foundation. (USA)

**Material Cross Reference Table**

SUS304	AISI 304
--------	----------

T08E.EPS